

OPG Proprietary	
Document Number: N-REP-01200-10000	Usage Classification: N/A
Sheet Number: N/A	Revision: R006

Title:

Use of Plant Parameters Envelope to Encompass the Reactor Designs being considered for the Darlington Site

© Ontario Power Generation Inc. (OPG), 2023. Proprietary/Confidential – Limited Use. This document and the information contained herein is the exclusive property of OPG. Disclosure of this document could reveal proprietary or confidential information of OPG, other governments or third parties; and/or prejudice intergovernmental relations or the economic interests of OPG or third parties, including the Government of Ontario. This document is being provided in accordance with regulatory requirements for OPG's Licence to Construct application filed October 2022 to construct one BWRX-300 reactor at OPG's Darlington site, and is not to be relied upon or to be used in connection with any other purpose.

Use of Plant Parameters Envelope to Encompass the Reactor Designs being considered for the Darlington Site**N-REP-01200-10000-R006**

2023-Jul-14

Order Number: N/A

Other Reference Number: N/A

OPG Proprietary

Prepared by: 
Jeremy McEachern
Senior Consultant
New Nuclear Design Engineering
Darlington New Nuclear Project

Verified by: 
Geoff Ruytenbeek
Assistant Technical Officer
Infrastructure Engineering
New Nuclear Design Engineering

Reviewed by:  14-Jul-2023
Daniel Cote
Manager - Infrastructure Engineering
New Nuclear Design Engineering
Darlington New Nuclear Project

Approved by:  18-Jul-2023
Paulina Herrera
Senior Manager - Design Engineering
DNNP Engineering, U1 Darlington New
Nuclear Project

Report

OPG Proprietary		
Document Number: N-REP-01200-10000		Usage Classification: N/A
Sheet Number: N/A	Revision Number: R006	Page: Page 2 of 147

Title:
Use of Plant Parameters Envelope to Encompass the Reactor Designs being considered for the Darlington Site

Table of Contents

	Page
List of Tables and Figures.....	3
Revision Summary.....	4
1.0 INTRODUCTION.....	5
2.0 DEVELOPMENT.....	5
3.0 CONCLUSION.....	7
4.0 REFERENCES.....	7
Appendix A: ... OPG's Plant Parameters Envelope Development Approach.....	9
Appendix B: ... Text Extracted from Candesco Report and Modified as Necessary	10
Attachment 1: Background on the Initiation and Application of the PPE Concept in the USA.....	115
Attachment 2: PPE Related Excerpts from the SERs for the ESP for the North Anna Site.....	117
Attachment 3: Description of Reactor Designs Being Considered for the Darlington Site.....	124

Report

OPG Proprietary		
Document Number: N-REP-01200-10000		Usage Classification: N/A
Sheet Number: N/A	Revision Number: R006	Page: Page 3 of 147

<small>Title:</small> Use of Plant Parameters Envelope to Encompass the Reactor Designs being considered for the Darlington Site
--

List of Tables and Figures

	Page
Table 1: PPE Parameter Characteristics.....	20
Table 2: PPE Parameter Characteristics.....	48
Table 3: Site Parameters and Darlington Characteristic Values, Composite Table	49
Table 3. 1: UHRS Spectral Acceleration and Frequency.....	58
Table 3. 2: Spectral Accelerations at 100 Hz	58
Table 3. 3: Tornado Missile Spectrum and Maximum Horizontal Speeds.....	59
Table 4: Consolidated PPE Parameters, Values, Where Used and How Used	59
Table 4. 1: Airborne Source Term, Single Reactor (Parameter 9.5.1)	95
Table 4. 2: Airborne Source Term, Prorated (Parameter 9.5.1).....	98
Table 4. 3: Liquid Effluent Source Term, Single Reactor (Parameter 10.3.1)	101
Table 4. 4: Liquid Effluent Source Term, Prorated (Parameter 10.3.1).....	104
Table 4. 5: Solid Radwaste Activity Levels, Single Reactor.....	107
Table 4. 6: Solid Radwaste Activity Levels, Prorated (Parameter 11.2.1).....	109
Table 4. 7: Blowdown Constituents and Concentrations	112
Table 4. 8: Yearly Emissions from Auxiliary Boilers, Single Unit	112
Table 4. 9: Yearly Emissions from Auxiliary Boilers, Prorated	112
Table 4. 10: Yearly Emissions From Standby Diesel Generators, Single Unit	113
Table 4. 11: Yearly Emissions From Standby Diesel Generators, Prorated.....	114

Report

OPG Proprietary		
Document Number: N-REP-01200-10000	Usage Classification: N/A	
Sheet Number: N/A	Revision Number: R006	Page: Page 4 of 147

Title:

Use of Plant Parameters Envelope to Encompass the Reactor Designs being considered for the Darlington Site

Revision Summary

Revision Number	Date	Comments
R000	2008-03-14	Initial issue.
R001	2008-08-14	Revised to include only the three reactor designs that are being considered in the Infrastructure Ontario Request for Proposal for new nuclear in Ontario. These are AECLs ACR-1000, Areva's US-EPR and Westinghouse's AP-1000. Some values for the AP-1000 have been changed per Westinghouse's response ([R-7] June 2008). This reflects design Revision 4 of the AP-1000. Some values for the ACR-1000 have been changed per AECL's response ([R-8] June 2008). Some values for the EPR have been changed per Areva's response ([R-9] July 2008).
R002	2009-03-11	Parameters 1.1.1 "Building Height" & 2.6.2 "Once Through Cooling – Cooling Water Flow Rate" changed from reactor class specific (RCS) to vendor design specific (VDS) per EA request. The parameter is moved from Tables 5 & 7 to Tables 4 & 6. Also updated Table 1 to reflect this change. Added "all others" radionuclides category to Tables 4.2 and 6.2 for both EPR and AP1000. Added noble gas values in Table 6.1.
R003	2010-11-24	Updated entire report for consistency with responses to information requests from Joint Review Panel. See previous revisions for full description.
R004	2022-8-15	Updated to include BWRX-300 plant parameters not bounded by R003 of the PPE
R005	2022-10-4	Updated Tables 4.1 to 4.4 with BWRX-300 specific values.
R006	2023-06-30	Updated parameters: <ul style="list-style-type: none"> • 9.5.1, annual activity, by isotope, contained in routine plant airborne effluent streams, • 10.3.1, annual activity, by isotope, contained in routine plant liquid effluent streams, and • 11.2.1, annual activity, by isotope, contained in solid radioactive wastes generated during routine plant operations. • Associated table 4.1 to 4.6 related to above parameters.

Report

OPG Proprietary		
Document Number:	N-REP-01200-10000	Usage Classification: N/A
Sheet Number:	N/A	Revision Number: R006
		Page: Page 5 of 147

Title:

Use of Plant Parameters Envelope to Encompass the Reactor Designs being considered for the Darlington Site

1.0 INTRODUCTION

This document is Revision 6 of the Plant Parameter Envelope (PPE). This revision incorporates updated BWRX-300 tables for radioisotopes for routine plant airborne effluent streams, and solid radioactive wastes generated during routine plant operations. Additionally, the PPE has been updated to reflect the BWRX-300 zero liquid effluent release strategy.

As described in Section 2.0 below, the PPE was developed to provide quantitative input to the Environmental Assessment (EA) for the Darlington New Nuclear Project (DNNP), per the Project Description for the Site Preparation, Construction and Operation of the Darlington New Nuclear Generating Station [R-1]. The PPE was developed to assist in evaluating the potential safety and environmental effects of the multiple reactor designs being considered for the site.

The concept of a PPE was developed in the United States for use in the Early Site Permit (ESP) process to resolve siting and environmental issues at a particular site before a reactor design has been chosen [R-1, Chapter 1]. The PPE is a listing of values that can be used in the EA and license applications to assist in predicting the potential safety and environmental effects of a nuclear generating station at a particular site. The concept has been accepted by the United States Nuclear Regulatory Commission (US NRC) and has been used successfully in various ESP applications. The PPE concept is also consistent with the Canadian Nuclear Safety Commission (CNSC) statement in Revision 1 of the CNSC Information Document INFO-0756 [R-12]; "An application for a Licence to Prepare Site does not require detailed information or determination of reactor design; however, high level design information is required for the environmental assessment that precedes the licensing decision for a Licence to Prepare Site."

The PPE is recognized as a bounding envelope of plant design and site characteristics in the licensing basis for DNNP [R-14]. The PPE was used during technology selection to demonstrate that the design of the facility fits within the values used. Where the BWRX-300 fell outside Revision 3 of the PPE, the design was either adjusted until it fit within the PPE, or where it could be demonstrated that the PPE value can be adjusted without introduction of unreasonable risk to the public, environment, or workers, the PPE is being revised to Revision 5 to document a new bounding envelope in these areas [R-13] [R-15].

2.0 DEVELOPMENT

The approach used by OPG in developing the PPE is described in Appendix A.

On June 6, 2007, OPG requested PPE information from six vendors for the nine reactor designs that were being considered at the time: the EC6 and ACR-1000 from AECL, the EPR from Areva, the ABWR and ESBWR from GE Hitachi, the OPR1000 and APR1400 from KHNP, the US-APWR from Mitsubishi, and the AP-1000 from Westinghouse.

Revision 0 of the PPE was developed by Candesco Corporation under contract to OPG. This encompassed the nine reactor designs originally considered. The values in the report were generated, reviewed and verified (based on a Quality Assurance Program compliant with CSA N286.2-00) and documented [R-6]. Power reactor vendors provided the numerical

OPG Proprietary		
Document Number: N-REP-01200-10000	Usage Classification: N/A	
Sheet Number: N/A	Revision Number: R006	Page: Page 6 of 147

Title:

Use of Plant Parameters Envelope to Encompass the Reactor Designs being considered for the Darlington Site

values used in the report. The vendor data were analyzed to determine the limiting value for each parameter. A bounding PPE was developed from the limiting value for each parameter. The PPE was then sent to the vendors to confirm that their design(s) was (were) bounded by it. Verification was received from AECL [R-2] and Areva [R-3]. An independent peer review of Revision 0 of the PPE was conducted by a third party [R-4]. The comments from this review were dispositioned and Revision 0 of the PPE was finalized [R-5].

In March 2008, Infrastructure Ontario (IO) issued a competitive Request for Proposal (RFP) for a new nuclear power station in Ontario. Four vendors were invited to participate in the RFP process: AECL (the ACR-1000), Areva (the EPR), GE-Hitachi (the ESBWR) and Westinghouse (the AP1000). GE-Hitachi chose not to participate in the process.

Since the number of reactors under consideration had been reduced from nine to three as a result of the IO RFP, it was deemed necessary to revise the PPE to reflect the bounding limits for the three remaining designs (the ACR-1000, the EPR and the AP-1000). Revision 1 of the PPE was developed and verified by OPG staff by editing the Revision 0. A third-party review was deemed unnecessary for Revision 1 of the PPE because the methodology in producing Revision 1 is unchanged from that in Revision 0. The revised PPE tables were sent to each vendor to confirm that their design is bounded by it. Verification was received from Westinghouse [R-7], AECL [R-8] and Areva [R-9] with some revised values. These changes were incorporated into Revision 2.

From December 2009 to October 2010, the Joint Review Panel (JRP) issued Information Requests (IRs) relating to the September 2009 Application for a Licence To Prepare Site (LTPS) and the Environmental Impact Statement (EIS) for the Darlington New Nuclear Project (DNNP). For the IRs related to PPE parameters, the responses prepared by OPG involved such things as:

- provision of where and how the PPE Revision 2 parameters were used in the LTPS and EIS documents;
- a listing of all PPE parameters and limiting values and technologies in a single, consolidated list, along with supporting tables;
- documenting Darlington site characteristic values and comparing them to corresponding PPE values;
- some parameter values for hybrid cooling towers; and,
- receipt of some updated vendor data (from AECL).

In August 2010, the JRP required OPG to re-evaluate the PPE to consider alternative technologies, to provide a description of them, to detail impacts on the EIS from their inclusion, and to provide any required updates to responses to information requests [R-11]. OPG provided this information to the JRP for the Enhanced CANDU 6 (EC6) heavy water reactor, in consultation with the EC6 vendor, AECL. This information was incorporated into R003 revision of the PPE.

In 2013 the Government of Ontario deferred the procurement of large new nuclear reactors at the Darlington site. In 2018, OPG began exploring the option of utilizing Small Modular Reactor (SMR) technologies at the DNNP site. Between 2019 and 2021 OPG worked through a technology selection and due diligence process and in December 2021 selected

Report

OPG Proprietary		
Document Number:	N-REP-01200-10000	Usage Classification: N/A
Sheet Number:	Revision Number: R006	Page: Page 7 of 147

Title:

Use of Plant Parameters Envelope to Encompass the Reactor Designs being considered for the Darlington Site

the BWRX-300 as the technology to be deployed at the DNNP site. The BWRX-300 technology has been evaluated against PPE and this R006 version of the PPE incorporates new values for radioisotopes for routine plant airborne effluent streams [R-16], and solid radioactive wastes [R-17] generated during routine plant operations. Additionally, radioisotopes in liquid effluent have been updated to reflect the zero liquid effluent release strategy.

3.0 CONCLUSION

The PPE is a set of data derived from available vendor information for multiple reactor designs and provides a bounding envelope of plant design and site parameter values that was used in the License to Prepare Site (LTPS) Application and Environmental Assessment (EA). It relates to the interaction between a nuclear power plant and the site/environment.

The PPE presented here bounds five (5) reactor designs: the four original technologies (AP1000, ACR-1000, EC6 and EPR) and the BWRX-300.

The PPE values used in the site evaluation studies resulted in the conclusion that a new nuclear power plant at the Darlington site would not pose an unreasonable risk to the public or environment.

Although some PPE values have changed as a result of the BWRX-300, as described in Section 4.3 of Reference [R-13], there is no impact to the EIS conclusions.

The revised PPE bounds the Darlington site characteristic values, demonstrating that the site for New Nuclear at Darlington is suitable for a new nuclear power plant.

4.0 REFERENCES

- [R-1] OPG Letter to CNSC, Jim Hankinson to I. Grant, "Site Preparation License – Darlington B, Project Description", April 17, 2007, N-CORR-00531-03863.
- [R-2] AECL Letter to OPG, Gary Leach to Pat McNeil, "AECL Response to OPG Request for Review of OPG Bounding Plant Parameter Envelope for Darlington Site", January 28, 2008, N-CORR-01210-0236799.
- [R-3] Areva Letter to OPG, Steve Hamilton to Pat McNeil, "Areva Response to OPG Request for Review of OPG Bounding Plant Parameter Envelope for Darlington Site", February 20, 2008, N-CORR-01210-0236741, marked OPG Confidential.
- [R-4] OPG Report, John Tribou, "Review of a Draft Plant Parameter Envelope", February 15, 2008, N-REP-01200-0236766.
- [R-5] Candesco Corporation Report, Evan Houldin, "The Use of Plant Parameters Envelope to Encompass the Reactor Designs Being Considered for the Darlington Site", March 17, 2008, CD# N-REP-01200-10000-R000.

Report

OPG Proprietary		
Document Number: N-REP-01200-10000	Usage Classification: N/A	
Sheet Number: N/A	Revision Number: R006	Page: Page 8 of 147

Title:

Use of Plant Parameters Envelope to Encompass the Reactor Designs being considered for the Darlington Site

- [R-6] Candesco Corporation Report, Evan Houldin, "QA Report for Candesco Corporation Plant Parameters Envelope (PPE) Report for the Darlington Site", March 15, 2008, N-REP-01200-0245869.
- [R-7] Westinghouse Letter to OPG, Michael Godfrey to Laurie Swami "Westinghouse Response to OPG Request for Review of OPG Bounding Plant Parameter Envelope for Darlington Site", July 01, 2008, N-CORR-01210-0254851.
- [R-8] AECL Letter to OPG, Gary Leach to Laurie Swami, "AECL Response to OPG Request for Review of OPG Bounding Plant Parameter Envelope for Darlington Site", June 27, 2008, N-CORR-01210-0254850.
- [R-9] Areva Letter to OPG, Steve Hamilton to Laurie Swami, "Areva Response to OPG Request for Review of OPG Bounding Plant Parameter Envelope for Darlington Site", July 16, 2008, N-CORR-01200-0254857.
- [R-10] Nuclear Energy Institute document, "Industry Guideline for Developing a Plant Parameter Envelope in Support of an Early Site Permit", March 2010, NEI 1001 [Revision 0].
- [R-11] Joint Review Panel letter, A. Graham to A. Sweetnam, "Darlington New Nuclear Power Plant Project – Joint Review Panel Response to Letter of August 17, 2010," August 20, 2010, CD# NK054-CORR-00531-00137.
- [R-12] Canadian Nuclear Safety Commission (CNSC). Licensing Process for New Nuclear Power Plants in Canada. Information Document INFO-0756. May 2008.
- [R-13] Darlington New Nuclear Project Environmental Impact Statement Review Report for Small Modular Reactor BWRX-300, NK054-REP-07730-00055 R000, September 2022.
- [R-14] LCH-DNNP-PRSL 18.00 2031, Darlington New Nuclear Project - Site Preparation Licence Conditions Handbook, May 20th, 2022.
- [R-15] GEOP-DNNP1-2022-0038, Ontario Power Generation (OPG) Darlington New Nuclear Project (DNNP) OPG Plant Parameters Envelope Rev 0 Summary, July 6th, 2022.
- [R-16] 007N1078 Revision 2, Annual Average Gaseous Effluent Releases for the BWRX-300 Standard Plant, June 2023.
- [R-17] DWM-03011-130-003, DNNP Technical Memo: BWRX-300 Waste Estimates Based Upon GEH Coolant Source Term, June 2023.

OPG Proprietary		
Document Number: N-REP-01200-10000	Usage Classification: N/A	
Sheet Number: N/A	Revision Number: R006	Page: Page 9 of 147

Title:
Use of Plant Parameters Envelope to Encompass the Reactor Designs being considered for the Darlington Site

Appendix A: OPG's Plant Parameters Envelope Development Approach

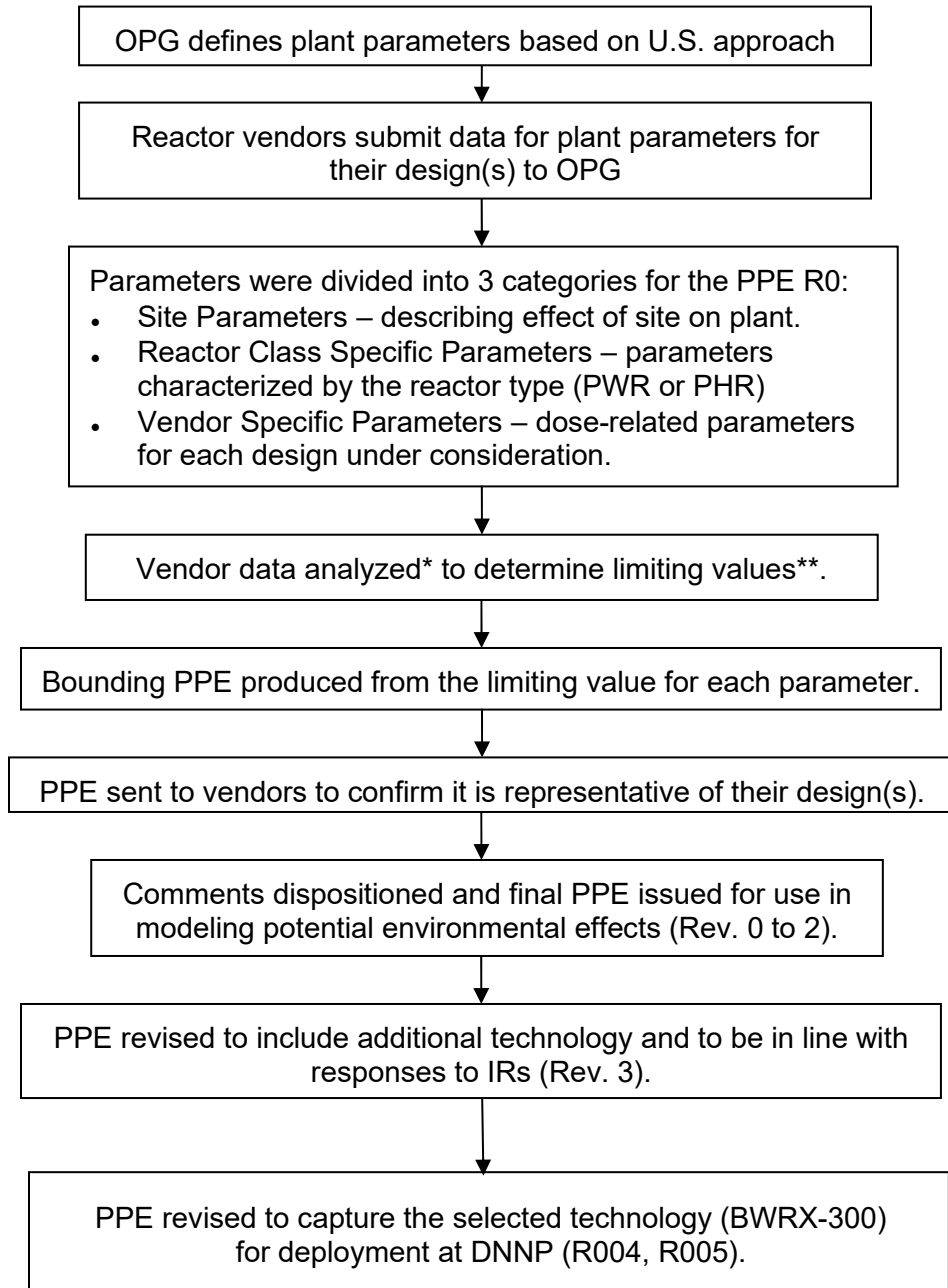

* Analysis includes cross-design comparison and comparison against equivalent parameter values accepted by the U.S. NRC.
 ** Limiting value: the value for each parameter that describes the greatest impact of the plant on the site, or of the site on the plant.

Report

OPG Proprietary		
Document Number: N-REP-01200-10000	Usage Classification: N/A	
Sheet Number: N/A	Revision Number: R006	Page: Page 10 of 147

Title:

Use of Plant Parameters Envelope to Encompass the Reactor Designs being considered for the Darlington Site

Appendix B: Text Extracted from Candesco Report and Modified as Necessary

B.1.0. BACKGROUND

Ontario Power Generation (OPG) has applied for a license to prepare the Darlington site for the future construction of additional nuclear power plants, where the selection of the candidate design for construction has not been finalized. A Plant Parameter Envelope (PPE), as described in this report, provides quantitative input in assessing the impact of a range of reactor designs on the site and the environment.

The PPE concept is also consistent with the Canadian Nuclear Safety Commission (CNSC) statement in Revision 1 of the CNSC Information Document INFO-0756 [R12]; "An application for a Licence to Prepare Site does not require detailed information or determination of reactor design; however, high level design information is required for the environmental assessment that precedes the licensing decision for a Licence to Prepare Site." The application of a PPE in the Environmental Assessment (EA) of the Darlington site provides a means to facilitate the assessment of a large number of parameters for a range of reactor designs.

The EA for a new nuclear power plant is a comprehensive study which involves, among other things, performing an assessment of "alternative means of carrying out the projects that are technically and economically feasible and the environmental effects of any such alternative means" (clause 16(2)(b) of the Canadian Environmental Assessment (CEA) Act). The use of a PPE provides:

- a) a means of comparing several nuclear reactor design options; and
- b) a clear summary of the limiting values of relevant parameters for those reactor designs that are addressed in the comprehensive study.

Nuclear power plants are part of the comprehensive study list (Class 1A Nuclear Facilities, greater than 25 MWth, section 19 (d), Comprehensive Study List

Regulations, SOR/94-638, Canadian Environmental Assessment Act, (CEA Act)). Therefore, the Joint Review Panel (JRP) is ensuring "that the public is provided with an opportunity...to participate in the comprehensive study" (clause 21.2 of the CEA Act). The use of a PPE helps to provide a clear delineation of the limits of the design factors being proposed for consideration in the EA for a range of reactor designs, in the absence of a final decision as to which reactor technology will ultimately be built at the Darlington site.

B.2.0. INTRODUCTION TO THE PLANT PARAMETER ENVELOPE (PPE) CONCEPT

PPEs were initiated and have been applied in the nuclear power reactor licensing process of the United States. Background information on the United States Nuclear Regulatory Commission's (USNRC's) review and acceptance of PPEs and licensee application of PPEs in the United States (US) is provided in Attachments 1 and 2.

Report

OPG Proprietary		
Document Number: N-REP-01200-10000	Usage Classification: N/A	
Sheet Number: N/A	Revision Number: R006	Page: Page 11 of 147

Title:

Use of Plant Parameters Envelope to Encompass the Reactor Designs being considered for the Darlington Site

A PPE is a tabular representation of the key features of the interfaces between a nuclear plant and the site and provides the quantitative values of these key features for a given nuclear plant design. A composite PPE can be constructed to describe a range of different nuclear plant designs by using the most limiting value from the different nuclear plant designs under consideration for each parameter in the composite PPE. Therefore, the use of a composite PPE allows the applicant to assess the environmental impact of a hypothetical plant design, formulated as a bounding construct from various reactor designs under consideration, on a selected site, even when a number of different nuclear reactor designs are being considered for the site. A composite PPE provides a bounding limit of reactor design impact for a range of nuclear power plant designs and their associated facilities. If the EA of a specific site is acceptable using a composite PPE to represent the reactor design, then the EA will be clearly acceptable for a specific reactor design that falls within the bounds of the composite PPE values.

From a safety assessment perspective, it is expected that the design characteristics of the reactor eventually selected for a site will place fewer requirements on site resources than the requirements placed by the limiting composite PPE design parameters. Similarly, it is expected that the environmental impact of the reactor design eventually selected for construction and operation at a specific site will be less than the impact for the limiting PPE design parameters.

B.3.0. SCOPE

Pursuant to clause 15(3) of the CEA Act, the environmental assessment for the Darlington site will address all phases of the project, including: construction, operation, modifications (i.e., channel replacement, future refurbishment and/or life extension work), decommissioning, abandonment or other undertakings in relation to the project that are, in the opinion of the CNSC, likely to be carried out in relation to the project. As a result, parameters relating to all of these phases are addressed in the PPE tables discussed in this report.

B.3.1. Interfaces between Proposed Site and Nuclear Plant

The following types of information regarding the interfaces between the proposed site and nuclear plant can be included in a PPE (composite or otherwise):

- the impact of the nuclear plant on the site's natural and environmental resources (e.g., potential increases in water and air temperatures, water use, gaseous and liquid releases of radioactive material);
- site characteristics that are required to support the safe operation of a nuclear plant (e.g., availability of cooling water, ambient air temperature, etc.); and
- the capability of the nuclear plant to withstand the natural and man-made environmental hazards associated with the site (e.g., earthquake, tornado, potential floods from nearby dams, snow load, rainfall, etc.).

Report

OPG Proprietary		
Document Number: N-REP-01200-10000	Usage Classification: N/A	
Sheet Number: N/A	Revision Number: R006	Page: Page 12 of 147

Title:

Use of Plant Parameters Envelope to Encompass the Reactor Designs being considered for the Darlington Site

B.3.2. Limiting Factors to Environmental Impact

From an environmental impact perspective, some of the factors that determine the selection of limiting values for the various design parameters being considered may include the:

- (a) tallest building height;
- (b) deepest embedment;
- (c) largest temperature increase associated with water and/or air being recycled back into the environment (e.g., normal plant heat sink, ultimate heat sink);
- (d) largest area of land usage (e.g., footprint of reactor buildings, parking lots, access roads, construction laydown areas, etc.);
- (e) greatest amount of heat rejected to the environment (i.e., atmosphere and/or bodies of water);
- (f) greatest usage (i.e., recycled back to environment) and/or consumption of water;
- (g) highest concentration of dissolved solids in water being recycled back into the environment;
- (h) greatest amount of air pollutants being recycled back into the environment (e.g., diesel and/or gas turbine emissions);
- (i) greatest airborne and/or liquid effluent release of radioactivity to the environment during normal operations and postulated accidents;
- (j) highest level of activity contained in solid waste stored at the site; and
- (k) greatest volume of high-level radioactive waste stored at the site.

B.4.0. TERMINOLOGY AND METHODOLOGY

As the PPE concept developed in the U.S., a number of definitions for key terms were formulated to facilitate discussion and understanding of the PPE approach and its application. For reference in the current report these definitions are as follows:

Site parameters:

Site parameters are the postulated physical, environmental and demographic features of an unspecified site. These are site-related parameters that a vendor would assume in the process of completing a reactor design. Site parameters establish the physical, environmental and demographic characteristics that a site must have in order for a vendor's reactor design to be compatible with the site. Therefore,

Report

OPG Proprietary		
Document Number: N-REP-01200-10000	Usage Classification: N/A	
Sheet Number: N/A	Revision Number: R006	Page: Page 13 of 147

Title:
Use of Plant Parameters Envelope to Encompass the Reactor Designs being considered for the Darlington Site

site parameters are considered primarily in reactor design and reactor safety assessment. Examples of site parameters would include the snow or wind loads that the buildings are designed to withstand.

Site parameters are addressed in a composite PPE. Given that the site is known, the actual characteristics of the Darlington site are used where possible to determine whether a particular reactor design is suitable for the site. Also, where possible the actual site characteristics are used in any safety assessments of the candidate reactors.

Design parameters:

Design parameters are the postulated design features of a reactor that could be constructed on a site. Design parameters describe design information that is necessary to prepare and review an Environmental Assessment. An example of a key design parameter would be the total thermal power output of the nuclear power plant. At the construction application stage, the design parameters from the PPE will be compared with the actual design characteristics of the selected nuclear reactor design to ensure that the design characteristics are bounded by the design parameters in the PPEs. If this is confirmed, then the conclusions of the EA are valid. However, the converse is not necessarily true, in that certain design characteristics (e.g., the height of the reactor building) could be found to exceed design parameters and yet the conclusions of the EA may still remain valid.

In previous versions of the PPE, a distinction was made between parameters that were Vendor Design Specific (VDS) and Reactor Class Specific (RCS). While all of these parameters were retained for Revision 3 of the PPE, the distinction between VDS and RCS parameters is no longer highlighted. Parameters are reported in a single, consolidated table (Table 4), both for unit and prorated values, along with 11 supporting tables (4.1 through 4.11). This use of a single, consolidated table with supporting tables is consistent with the US PPE approach (Nuclear Energy Institute, Industry Guideline for Developing a Plant Parameter Envelope in support of an Early Site Permit, March 2010, Appendix B).

Site characteristics:

Site characteristics are the actual physical, environmental and demographic features of the proposed site for a new nuclear plant. These values are established through data collection and/or analysis and are provided, where appropriate, to support the Site Evaluation and EA of a new nuclear plant at the Darlington site. Examples of site characteristics include the maximum expected snowfall or sustained wind velocities at the site. At the construction application stage, the Darlington site characteristics will be compared to the design characteristics of the nuclear plant selected for construction to confirm that the reactor design is suitable for the site. For now, at the Application for Licence to Prepare Site stage, the PPE bounding values have been compared to Darlington characteristic site values and have been determined to bound site values (Table 3).

Design characteristics:

Design characteristics are the actual design features of a nuclear reactor. At the construction license application stage, the design characteristics of the nuclear reactor selected for construction are assessed to ensure they fall within the design parameters addressed in the EA.

Report

OPG Proprietary		
Document Number: N-REP-01200-10000	Usage Classification: N/A	
Sheet Number: N/A	Revision Number: R006	Page: Page 14 of 147

Title:
Use of Plant Parameters Envelope to Encompass the Reactor Designs being considered for the Darlington Site

B.5.0. PRESENTATION OF PLANT PARAMETER ENVELOPE DATA

The PPE is presented in the following tables:

Table	Type of Parameters	Description
Table 1	Overview of PPE Parameters	Summary of all parameters, definitions, units, whether the limit is a maximum or minimum, and whether it is subjected to being prorated.
Table 2	Summary of Reactor Designs	Overview of major reactor design characteristics.
Table 3	Site PPE Parameter	A set of site parameters that represent the composite bounding value for all reactor designs (Considered primarily in reactor design and reactor safety assessment), as well as the Darlington site characteristic values, and confirmation that the PPE limiting value bounds the Darlington site value.
Table 4 (Single Unit and Prorated)	All Parameters	A consolidation of all parameters, including the limiting value, the limiting technology, and where and how the parameter was used in the Site Evaluation Studies and the Environmental Impact Statement

The original Nuclear Energy Institute (NEI) numerical identifiers and names for the majority of the parameters (refer to Table 1) are maintained throughout the tables presented in this report. A limited number of parameters that relate to the overall plant thermal/electric characteristics are grouped into a new category, which appears at the beginning of Table 1 and Table 4 and are given numerical identifiers prefaced with 0.

Notes on the Organization of the Tables:

Table 1 provides a summary of the parameters included in the PPE for use in the LTPS and the EA of the Darlington site, as well as in the assessment of alternate reactor designs for the site. As such, Table 1 includes both site parameters (i.e., main application in reactor design and safety assessment) as well as design parameters (i.e., main application in environmental assessment). The parameters listed in Table 1 are consistent with those parameters addressed by the USNRC in the Safety

Evaluation Reports (SER) and Environmental Impact Statements (EIS) for the North Anna (SER: NUREG-1835, EIS: NUREG-1811), Grand Gulf (SER: NUREG-1840, EIS: NUREG-1817) and Clinton (SER: NUREG-1844, EIS: NUREG-1815) sites. The parameters included in Table 1 are also consistent with the original PPE worksheet formulated by the NEI (refer to letter from R.L. Simard (NEI)

Report

OPG Proprietary		
Document Number: N-REP-01200-10000	Usage Classification: N/A	
Sheet Number: N/A	Revision Number: R006	Page: Page 15 of 147

Title:

Use of Plant Parameters Envelope to Encompass the Reactor Designs being considered for the Darlington Site

to J.B. Lyons (USNRC), ESP Plant Parameters Envelope Worksheet, February 07, 2003). Table 1 does not include parameters that relate to design features that are no longer of interest to OPG. For example, OPG has decided to not use cooling ponds for normal plant heat sink or ultimate plant heat sink applications since these types of ponds would be excessively large for the Darlington site.

Also provided in Table 1 is a summary of:

- (a) the definitions and the units of the parameters;
- (b) whether the parameter is limiting when its value is at its maximum or minimum; and,
- (c) whether a parameter value is prorated based on the number of reactors that can be placed at the Darlington site.

In previous versions of the PPE, parameters were also described as being reactor class or vendor specific design parameters or site parameters. This is not done in this revision of the PPE because now a different table structure is used, consistent with information requests (IRs) received from the JRP.

Table 2 provides a summary of the reactors that have been considered in the generation of the PPE tables. There are two PWRs, Areva's EPR and Westinghouse's AP-1000. There is one PHR, the ACR-1000, and one PHWR, the EC6, both designed by Atomic Energy of Canada Limited (AECL). Brief descriptions of these various reactor designs are provided in Attachment 3.

Table 2 further provides a summary of the gross power, station power requirements termed as "house power" and net power in megawatts electric (MWe) for the various reactor designs. The Darlington project description is to construct nuclear power reactors to provide for a maximum of an additional 4800 MWe to the grid. The net powers from Table 2 are used to determine the number of reactors, as a function of reactor design, which could be built at the Darlington site given the additional power limit of 4800 MWe net to the grid. Also, space limitations at the Darlington site preclude more than four additional reactors being built. Four units of the following reactor designs could be built at the Darlington site: the AP-1000, the ACR-1000 and the EC6. Due to their larger electrical output per reactor, only three units of EPR design could be built at the Darlington site.

Table 3 provides Darlington site parameters that will be needed as input to reactor safety assessments, as well as for assessing which reactor designs are suitable for the site. The vendors supplied OPG with values for the site parameters that were assumed in the design of their plants (i.e., in the absence of a specific site). OPG has compared these site parameters (e.g., snow loads, earthquake values, tornado characteristics) to the Darlington site characteristics to ensure that the various reactor designs of interest are suitable for the Darlington site.

Table 4 is a consolidated list of all of the 198 parameters of interest to OPG for the DNNP, providing both unit and prorated limiting values, identifying the limiting reactor(s) in each case, and listing where and how the parameters have been used in the site evaluation studies (SESS) and the EA.

Thus, Table 4 includes the parameters shown in Table 3, as well as parameters that were formerly tabulated separately as Vendor Design Specific (VDS) parameters and Reactor Class Specific (RCS)

Report

OPG Proprietary		
Document Number: N-REP-01200-10000	Usage Classification: N/A	
Sheet Number: N/A	Revision Number: R006	Page: Page 16 of 147

Title:
Use of Plant Parameters Envelope to Encompass the Reactor Designs being considered for the Darlington Site

parameters. Table 4 now includes parameters related to dose, source terms and fuel storage, and which address the nuclear-related environmental consequences of siting additional reactors at the Darlington site. Supporting tables are provided for:

- parameter 9.5.1 (i.e., the annual activity, by isotope, contained in routine plant airborne effluent streams, refer to Tables 4.1 (unit) and 4.2 (prorated));
- parameter 10.3.1 (i.e., the annual activity, by isotope, contained in routine plant effluent streams, refer to Tables 4.3 (unit) and 4.4 (prorated)); and,
- parameter 11.2.1 (i.e., the annual activity, by isotope, contained in the solid radioactive wastes generated by routine plant operations, refer to Tables 4.5 (unit) and 4.6 (prorated)).

Tables 4.1 through 4.6 for normal operating airborne releases, effluent releases and solid waste activity levels, provide a summary of the information supplied by the vendors and show the activity breakdown as a function of various isotopes. Note that the vendors provided identical solid radwaste related information for NEI parameter 11.2.2 (Principal Radionuclides). Therefore, parameter 11.2.2 from the original NEI table is not considered further in this report.

Note that accounting for multiple units at the Darlington site can have an impact on the selection of the limiting reactor for the parameters. There are some parameters for which the value for multiple units will be greater than the single unit value, but not greater by the number of units on site. These parameters are covered under note 1 in Table 1.

Although Table 4 itself only provides the limiting value for each of the 198 parameters (one bounding value, one limiting technology for each parameter), some of the supporting tables provide values for all four technologies. Supporting tables 4.1 through 4.6, 4.8 and 4.9 all provide the available data for all four technologies. The other three tables (4.7, 4.10, and 4.11) present the limiting value and the one corresponding technology for each attribute.

B.6.0. DOSE ASSESSMENT

Given that the environmental assessment is being performed for a set of reactor design parameters that bound different reactor designs, it is appropriate in the PPE to use the regulatory dose limits for normal operations and accidents as the dose-related acceptance criteria.

Information is provided in Tables 4.1 through 4.4 on the activity releases from gaseous and liquid effluents that would occur during normal operation of the nuclear power plants. These releases are provided for all the reactor designs under consideration in this PPE. Estimates of the normal operation doses to the public were based on these activity releases.

B.7.0. ACRONYMS USED IN THE REPORT, TABLES AND REACTOR DESCRIPTIONS

ABWR	Advanced Boiling Water Reactor
ACR	Advanced CANDU Reactor
ACS	Atmospheric Control System

Report

OPG Proprietary		
Document Number: N-REP-01200-10000		Usage Classification: N/A
Sheet Number: N/A	Revision Number: R006	Page: Page 17 of 147

Title:

Use of Plant Parameters Envelope to Encompass the Reactor Designs being considered for the Darlington Site

ADS	Automatic Depressurization System
AECL	Atomic Energy of Canada Ltd.
AP	Advanced Passive
BWR	Boiling Water Reactor
CANDU	Canada Deuterium Uranium
CCWS	Component Cooling Water System
CEA	Canadian Environmental Assessment
CEA	Control Element Assembly
CFR	Code of Federal Regulations
CFS	Cavity Flooding System
CMT	Core Makeup Tank
CNSC	Canadian Nuclear Safety Commission
COL	Combined License
CP	Construction Permit
CS	Containment Spray
CSA	Canadian Standards Association
CT	Calandria Tube
DB	Dry Bulb
DBA	Design Basis Accident
DBE	Design Basis Earthquake
DOE	Department of Energy
EA	Environmental Assessment
EAB	Exclusion Area Boundary
EBS	Extra Borating System
EC6	Enhanced CANDU-6
ECCS	Emergency Core Cooling System
ECI	Emergency Coolant Injection
ECSBS	Emergency Containment Spray Backup System
EFW	Emergency Feedwater
EIS	Environmental Impact Statement
EPR	Evolutionary Power Reactor
EPRI	Electric Power Research Institute
ERV	External Reactor Vessel Cooling
ESBWR	Economic Simplified Boiling Water Reactor
ESP	Early Site Permit
ESPDP	Early Site Permit Demonstration Program
FCS	Flammability Control System
GDCCS	Gravity Driven Core Cooling System
GEH	General Electric Hitachi
HG	Containment Hydrogen Control
HPCF	High Pressure Core Flooder
HPSIP	High Pressure Safety Injection Pump
HTS	Heat Transport System
HVAC	Heating Ventilation and Air Conditioning
HVT	Holdup Volume Tank
ICS	Isolation Condenser System

Report

OPG Proprietary		
Document Number: N-REP-01200-10000		Usage Classification: N/A
Sheet Number: N/A	Revision Number: R006	Page: Page 18 of 147

Title:

Use of Plant Parameters Envelope to Encompass the Reactor Designs being considered for the Darlington Site

IO	Infrastructure Ontario
IRWST	In-containment Refuelling Water Storage Tank
IW	In-containment Water Storage
KEPCO	Korea Electric Power Corporation
KHNP	Korea Hydro and Nuclear Power
KSF	One thousand pounds per square foot
LEU	Lightly Enriched Uranium
LHSI	Low Head Safety Injection
LOCA	Loss of Coolant Accident
LPFL	Low Pressure Flooding
LPSIP	Low Pressure Safety Injection Pump
LPZ	Low Population Zone
LT	Limiting Table
LTC	Long Term Cooling
MCCI	Molten Core Concrete Interaction
MHSI	Medium Head Safety Injection
MOX	Mixed Oxide
MSLB	Main Steam Line Break
MWe	Megawatts electric
MWth	Megawatts thermal
NEI	Nuclear Energy Institute
OPG	Ontario Power Generation
OPR	Optimized Power Reactor
PAR	Passive Autocatalytic Recombiner
PCCS	Passive Containment Cooling System
PCS	Passive Containment Cooling System
PHR	Pressurized Hybrid Reactor
PHWR	Pressurized Heavy Water Reactor
PMP	Probable Maximum Precipitation
PPE	Plant Parameter Envelope
PRHR	Passive Residual Heat Removal System
PT	Pressure Tube
PWR	Pressurized Water Reactor
PXS	Passive Core Cooling System
RAI	Request for Additional Information
RCCA	Rod Cluster Control Assembly
RCCV	Reinforced Concrete Containment Vessel
RCIC	Reactor Core Isolation Cooling System
RCP	Reactor Coolant Pump
RCS	Reactor Coolant System
RCS PPE	Reactor Class Specific Plant Parameter Envelope
RDT	Rapid Depressurization Tank
RFP	Request for Proposal
RHR	Residual Heat Removal
RHRS	Residual Heat Removal System
RIP	Reactor Internal Pumps

Report

OPG Proprietary		
Document Number: N-REP-01200-10000		Usage Classification: N/A
Sheet Number: N/A	Revision Number: R006	Page: Page 19 of 147

Title:

Use of Plant Parameters Envelope to Encompass the Reactor Designs being considered for the Darlington Site

RPV	Reactor Pressure Vessel
RRS	Reactor Regulating System
RWS	Reserve Water System
RWSP	Refuelling Water Storage Pit
RWT	Recirculation Water Tank
S&PC	Steam and Power Conversion
SBWR	Simplified Boiling Water Reactor
SDS	Shutdown System
SER	Safety Evaluation Report
SGTS	Standby Gas Treatment System
SIP	Safety Injection Pump
SIS	Safety Injection System
SIT	Safety Injection Tank
SLCS	Standby Liquid Control System
SMR	Small Modular Reactor
SNL	Sandia National Laboratories
SSAR	Site Safety Analysis Report
TEDE	Total Effective Dose Equivalent
UHRS	Uniform Hazard Response Spectrum
UHS	Ultimate Heat Sink
UHS HX	Ultimate Heat Sink Heat Exchanger
UO2	Uranium Dioxide
URD	Utility Requirements Document
USNRC	U.S. Nuclear Regulatory Commission
VDS	Vendor Design Specific
WB	Wet Bulb

Report

OPG Proprietary		
Document Number: N-REP-01200-10000	Usage Classification: N/A	
Sheet Number: N/A	Revision Number: R006	Page: Page 20 of 147

Title:
Use of Plant Parameters Envelope to Encompass the Reactor Designs being considered for the Darlington Site

B.8.0. PLANT PARAMETER ENVELOPE TABLES

B.1.1 Table 1 PPE Parameter Characteristics

Table 1: PPE Parameter Characteristics

PPE Parameter	Units	Definition	Characteristic of Limiting Parameter Value	Parameter Value to be Prorated Based on Number of Units on Site?
0. Plant thermal/electric characteristics				
0.1 Electric Output	MW	The electrical output of the plant	maximum	yes
0.2 Megawatts Thermal	MW	The thermal output of the plant, including electrical output and rejected heat load	maximum	yes
0.3 Station Capacity Factor	%	The percentage of time the plant is expected to deliver its stated electrical output over the lifetime of the plant, considering all expected outages	maximum	no
0.4 Plant Design Life	years	The designed lifetime of the plant, including planned midlife refurbishments	maximum	no
1. Structure				
1.1 Building Characteristics				
1.1.1 Height	m (ft)	The height from finished grade to the top of the tallest power block structure, excluding cooling towers	maximum	no
1.1.2 Foundation Embedment	m (ft)	The depth from finished grade to the bottom of the basemat for the most deeply embedded power block structure	maximum	no
1.2 Precipitation (for Roof Design)				

Report

OPG Proprietary		
Document Number: N-REP-01200-10000		Usage Classification: N/A
Sheet Number: N/A	Revision Number: R006	Page: Page 21 of 147

Title:
Use of Plant Parameters Envelope to Encompass the Reactor Designs being considered for the Darlington Site

PPE Parameter	Units	Definition	Characteristic of Limiting Parameter Value	Parameter Value to be Prorated Based on Number of Units on Site?
1.2.1 Maximum Rainfall Rate	cm per hour and cm in 5 minutes (inches per hour/ inches in 5 minutes)	The Probable Maximum Precipitation (PMP) value that can be accommodated by a plant design. Expressed as maximum precipitation for 1 hour in 1 square km and as maximum precipitation for 5 minutes in 1 square km	minimum	no
1.2.2 Snow & Ice Load	pascals (pounds per square foot)	The maximum load on structure roofs due to the accumulation of snow and ice that can be accommodated by a plant design	minimum	no
1.3 Design Basis Earthquake (DBE)				
1.3.1 Design Response Spectra		The assumed design response spectra used to establish a plant's seismic design	N/A	no
1.3.2 Design Peak Ground Acceleration	fraction of gravity acceleration	The maximum earthquake ground acceleration for which a plant is designed, this is defined as the acceleration which corresponds to the zero period in the response spectra taken in the free field at plant grade elevation	minimum	no
1.3.3 Time History	N/A	The plot of earthquake ground motion as a function of time used to establish a plant's seismic design	minimum	no
1.3.4 Capable Tectonic Structures or Sources	N/A	The assumption made in a plant design about the presence of capable faults or earthquake sources in the vicinity of the plant site (e.g., No fault displacement potential within the investigative area)	minimum	no
1.4 Site Water Level (Allowable)				

Report

OPG Proprietary		
Document Number: N-REP-01200-10000		Usage Classification: N/A
Sheet Number: N/A	Revision Number: R006	Page: Page 22 of 147

Title:
Use of Plant Parameters Envelope to Encompass the Reactor Designs being considered for the Darlington Site

PPE Parameter	Units	Definition	Characteristic of Limiting Parameter Value	Parameter Value to be Prorated Based on Number of Units on Site?
1.4.1 Maximum Flood (or Tsunami)	m (ft)	Design assumption regarding the difference in elevation between finished plant grade and the water level due to the probable maximum flood (or Tsunami)	minimum (i.e., lowest elevation)	no
1.4.2 Maximum Ground Water	m (ft)	Design assumption regarding the difference in elevation between finished plant grade and the maximum site ground water level used in the plant design	minimum (i.e., lowest elevation)	no
1.5 Soil Properties Design Bases				
1.5.1 Liquefaction	N/A	Design assumption regarding the presence of potentially liquefying soils at a site	minimum	no
1.5.2 Minimum Required Bearing Capacity (Static)	pascals (ksf)	Design assumption regarding the capacity of the competent load-bearing layer required to support the loads exerted by plant structures used in the plant design	maximum	no
1.5.3 Minimum Shear Wave Velocity	m/s (feet per second)	The assumed limiting propagation velocity of shear waves through the foundation materials used in the plant design	maximum	no
1.6 Design Basis Tornado				
1.6.1 Maximum Pressure Drop	pascals (pounds per square inch)	The design assumption for the decrease in ambient pressure from normal atmospheric pressure due to the passage of the tornado	minimum	no
1.6.2 Maximum Rotational Speed	km/h (miles per hour)	The design assumption for the component of tornado wind speed due to the rotation within the tornado	minimum	no

Report

OPG Proprietary		
Document Number: N-REP-01200-10000		Usage Classification: N/A
Sheet Number: N/A	Revision Number: R006	Page: Page 23 of 147

Title:
Use of Plant Parameters Envelope to Encompass the Reactor Designs being considered for the Darlington Site

PPE Parameter	Units	Definition	Characteristic of Limiting Parameter Value	Parameter Value to be Prorated Based on Number of Units on Site?
1.6.3 Maximum Translational Speed	km/h (miles per hour)	The design assumption for the component of tornado wind speed due to the movement of the tornado over the ground	minimum	no
1.6.4 Maximum Wind Speed	km/h (miles per hour)	The design assumption for the sum of maximum rotational and maximum translational wind speed components	minimum	no
1.6.5 Missile Spectra	units as appropriate	The design assumptions regarding missiles that could be ejected either horizontally or vertically from a tornado. The spectra identify mass, dimensions and velocity of credible missiles.	range provided	no
1.6.6 Radius of Maximum Rotational Speed	m (ft)	The design assumption for distance from the centre of the tornado at which the maximum rotational wind speed occurs	maximum	no
1.6.7 Rate of Pressure Drop	pascals/s (pounds per square inch/s)	The assumed design rate at which the pressure drops due to the passage of the tornado	minimum	no
1.7 Wind				
1.7.1 Basic Wind Speed	km/h (miles per hour)	The design wind for which the facility is designed	minimum	no
1.7.2 Importance factors	N/A	Multiplication factors (as defined in ANSI A58 1-1982) applied to basic wind speed to develop the plant design	minimum	no
<u>2. Normal Plant Heat Sink</u>				
2.1 Ambient Air Requirements	°C (°F)			

Report

OPG Proprietary		
Document Number: N-REP-01200-10000		Usage Classification: N/A
Sheet Number: N/A	Revision Number: R006	Page: Page 24 of 147

Title: **Use of Plant Parameters Envelope to Encompass the Reactor Designs being considered for the Darlington Site**

PPE Parameter	Units	Definition	Characteristic of Limiting Parameter Value	Parameter Value to be Prorated Based on Number of Units on Site?
2.1.1 Normal Shutdown Max. Ambient Temp (1% Exceedance)	°C (°F)	Assumption used for the maximum ambient temperature that will be exceeded no more than 1% of the time, to design plant systems capable of effecting normal shutdown under the assumed temperature condition	minimum	no
2.1.2 Normal Shutdown Max Wet Bulb Temp (1% Exceedance)	°C (°F)	Assumption used for the maximum wet bulb temperature that will be exceeded no more than 1% of the time - used in design of plant systems that must be capable of effecting normal shutdown under the assumed temperature condition	minimum	no
2.1.3 Normal Shutdown Min Ambient Temp (1% Exceedance)	°C (°F)	Assumption used for the minimum ambient temperature that will be exceeded no more than 1% of the time to design of plant systems that must be capable of effecting normal shutdown under the assumed temperature condition	maximum	no
2.1.4 Rx Thermal Power Max Ambient Temp (0% Exceedance)	°C (°F)	Assumption used for the maximum ambient temperature that will never be exceeded - used in design of plant systems that must be capable of supporting full power operation under the assumed temperature condition	minimum	no
2.1.5 Rx Thermal Power Max Wet Bulb Temp (0% Exceedance)	°C (°F)	Assumption used for the maximum wet bulb temperature that will never be exceeded - used in design of plant systems that must be capable of supporting full power operation under the assumed temperature condition	minimum	no
2.1.6 Rx Thermal Power Min Ambient	°C (°F)	Assumption used for the minimum ambient temperature that will never	maximum	no

Report

OPG Proprietary		
Document Number: N-REP-01200-10000		Usage Classification: N/A
Sheet Number: N/A	Revision Number: R006	Page: Page 25 of 147

Title:
Use of Plant Parameters Envelope to Encompass the Reactor Designs being considered for the Darlington Site

PPE Parameter	Units	Definition	Characteristic of Limiting Parameter Value	Parameter Value to be Prorated Based on Number of Units on Site?
Temp (0% Exceedance)		be exceeded - used in design of plant systems that must be capable of supporting full power operation under the assumed temperature condition		
2.2 Blowdown Pond Acreage (24 hr blowdown)	square kilometres (acres)	The land usage required to provide a pond with a capacity to provide holdup for 24 hours of blowdown water from the plant.	maximum	yes
2.3 Condenser				
2.3.1 Max Inlet Temp Condenser / Heat Exchanger	°C (°F)	Design assumption for the maximum acceptable circulating water temperature at the inlet to the condenser or cooling water system heat exchangers	minimum	no
2.3.2 Condenser / Heat Exchanger Duty	watts (BTU per hour)	Design value for the waste heat rejected to the circulating water system across the condensers	maximum	yes
2.4 Mechanical Draft Cooling Towers				
2.4.1 Acreage	square kilometres (acres)	The land required for cooling towers or ponds, including support facilities such as equipment sheds, basins, canals, or shoreline buffer areas	maximum	yes
2.4.2 Approach Temperature	°C (°F)	The difference between the cold water temperature and the ambient wet bulb temperature	minimum	no
2.4.3 Blowdown Constituents and Concentrations	parts per million	The maximum expected concentrations for anticipated constituents in the cooling water systems blowdown to the receiving water body	maximum	no
2.4.4 Blowdown Flow Rate	litres per second	The normal (and maximum) flow rate of the blowdown stream from the	maximum	yes

Report

OPG Proprietary		
Document Number: N-REP-01200-10000		Usage Classification: N/A
Sheet Number: N/A	Revision Number: R006	Page: Page 26 of 147

Title:
Use of Plant Parameters Envelope to Encompass the Reactor Designs being considered for the Darlington Site

PPE Parameter	Units	Definition	Characteristic of Limiting Parameter Value	Parameter Value to be Prorated Based on Number of Units on Site?
	(gallons per minute)	cooling water systems to the receiving water body for closed system designs		
2.4.5 Blowdown Temperature	°C (°F)	The maximum expected blowdown temperature at the point of discharge to the receiving water body	maximum	no
2.4.6 Cycles of Concentration	number	The ratio of total dissolved solids in the cooling water blowdown streams to the total dissolved solids in the makeup water streams	maximum	no
2.4.7 Evaporation Rate	litres per second (gallons per minute)	The expected (and maximum) rate at which water is lost by evaporation from the cooling water systems	maximum	yes
2.4.8 Height	m (ft)	The vertical height above finished grade of mechanical draft cooling towers associated with the cooling water systems	maximum	no
2.4.9 Makeup Flow Rate	litres per second (gallons per minute)	The expected (and maximum) rate of removal of water from a natural source to replace water losses from closed cooling water systems	maximum	yes
2.4.10 Noise	decibels	The maximum expected sound level produced by operation of cooling towers, measured at 1000 feet from the noise source	maximum	no
2.4.11 Cooling Tower Temperature Range	°C (°F)	The temperature difference between the cooling water entering and leaving the towers	minimum	no
2.4.12 Cooling Water Flow Rate	litres per second		maximum	yes

Report

OPG Proprietary		
Document Number: N-REP-01200-10000		Usage Classification: N/A
Sheet Number: N/A	Revision Number: R006	Page: Page 27 of 147

Title:
Use of Plant Parameters Envelope to Encompass the Reactor Designs being considered for the Darlington Site

PPE Parameter	Units	Definition	Characteristic of Limiting Parameter Value	Parameter Value to be Prorated Based on Number of Units on Site?
	(gallons per minute)	The total cooling water flow rate through the condenser / heat exchangers		
2.4.13 Heat Rejection Rate (blowdown)	litres per second @ °C (gallons per minute @ °F)	The expected heat rejection rate to a receiving water body, expressed as flow rate in litres per second at a temperature in degrees celsius	maximum	yes
2.4.14 Maximum Consumption of Raw Water	litres per second (gallons per minute)	The expected maximum short-term consumptive use of water by the cooling water systems (evaporation and drift losses)	maximum	yes
2.4.15 Monthly Average Consumption of Raw Water	litres per second (gallons per minute)	The expected normal operating consumption of water by the cooling water systems (evaporation and drift losses)	maximum	yes
2.4.16 Stored Water Volume	litres (gallons)	The quantity of water stored in cooling water system impoundments, basins, tanks and/or ponds	maximum	yes
2.5 Natural Draft Cooling Towers				
2.5.1 Acreage	square kilometres (acres)	The land required for cooling towers or ponds, including support facilities such as equipment sheds, basins, canals, or shoreline buffer areas	maximum	yes
2.5.2 Approach Temperature	°C (°F)	The difference between the cold water temperature and the ambient wet bulb temperature.	minimum	no
2.5.3 Blowdown Constituents and Concentrations	parts per million	The maximum expected concentrations for anticipated constituents in the cooling water systems blowdown to the receiving water body	maximum	no

Report

OPG Proprietary		
Document Number: N-REP-01200-10000		Usage Classification: N/A
Sheet Number: N/A	Revision Number: R006	Page: Page 28 of 147

Title:
Use of Plant Parameters Envelope to Encompass the Reactor Designs being considered for the Darlington Site

PPE Parameter	Units	Definition	Characteristic of Limiting Parameter Value	Parameter Value to be Prorated Based on Number of Units on Site?
2.5.4 Blowdown Flow Rate	litres per second (gallons per minute)	The normal (and maximum) flow rate of the blowdown stream from the cooling water systems to the receiving water body for closed system designs	maximum	yes
2.5.5 Blowdown Temperature	°C (°F)	The maximum expected blowdown temperature at the point of discharge to the receiving water body	maximum	no
2.5.6 Cycles of Concentration	number	The ratio of total dissolved solids in the cooling water blowdown streams to the total dissolved solids in the makeup water streams	maximum	no
2.5.7 Evaporation Rate	litres per second (gallons per minute)	The expected (and maximum) rate at which water is lost by evaporation from the cooling water systems	maximum	yes
2.5.8 Height	m (ft)	The vertical height above finished grade of natural draft cooling towers associated with the cooling water systems	maximum	no
2.5.9 Makeup Flow Rate	litres per second (gallons per minute)	The expected (and maximum) rate of removal of water from a natural source to replace water losses from closed cooling water systems	maximum	yes
2.5.10 Noise	decibels	The maximum expected sound level produced by operation of cooling towers, measured at 1000 feet from the noise source	maximum	no
2.5.11 Cooling Tower Temperature Range	°C (°F)	The temperature difference between the cooling water entering and leaving the towers	minimum	no

Report

OPG Proprietary		
Document Number: N-REP-01200-10000		Usage Classification: N/A
Sheet Number: N/A	Revision Number: R006	Page: Page 29 of 147

Title: **Use of Plant Parameters Envelope to Encompass the Reactor Designs being considered for the Darlington Site**

PPE Parameter	Units	Definition	Characteristic of Limiting Parameter Value	Parameter Value to be Prorated Based on Number of Units on Site?
2.5.12 Cooling Water Flow Rate	litres per second (gallons per minute)	The total cooling water flow rate through the condenser / heat exchangers	maximum	yes
2.5.13 Heat Rejection Rate (blowdown)	litres per second @ °C (gallons per minute @ °F)	The expected heat rejection rate to a receiving water body, expressed as flow rate in litres per second at a temperature in degrees celsius	maximum	yes
2.5.14 Maximum Consumption of Raw Water	litres per second (gallons per minute)	The expected maximum short-term consumptive use of water by the cooling water systems (evaporation and drift losses)	maximum	yes
2.5.15 Monthly Average Consumption of Raw Water	litres per second (gallons per minute)	The expected normal operating consumption of water by the cooling water systems (evaporation and drift losses)	maximum	yes
2.5.16 Stored Water Volume	litres (gallons)	The quantity of water stored in cooling water system impoundments, basins, tanks and/or ponds	maximum	yes
2.6 Once-Through Cooling				
2.6.1 Cooling Water Discharge Temperature	°C (°F)	Expected temperature of the cooling water at the exit of the condenser/heat exchangers	maximum	no
2.6.2 Cooling Water Flow Rate	litres per second (gallons per minute)	Total cooling water flow rate through the condenser (also the rate of withdrawal from and return to the water source)	maximum	yes

Report

OPG Proprietary		
Document Number: N-REP-01200-10000		Usage Classification: N/A
Sheet Number: N/A	Revision Number: R006	Page: Page 30 of 147

Title:
Use of Plant Parameters Envelope to Encompass the Reactor Designs being considered for the Darlington Site

PPE Parameter	Units	Definition	Characteristic of Limiting Parameter Value	Parameter Value to be Prorated Based on Number of Units on Site?
2.6.3 Cooling Water Temperature Rise	°C (°F)	Temperature rise across the condenser (temperature of water out minus temperature of water in)	maximum	no
2.6.4 Evaporation Rate	litres per second (gallons per minute)	The expected (and maximum) rate at which water is lost by evaporation from the receiving water body as a result of heating in the condenser.	maximum	yes
2.6.5 Heat Rejection Rate	watts (BTU per hour)	The expected heat rejection rate to a receiving water body	maximum	yes
2.7 Hybrid Cooling Towers				
2.7.1 Acreage	square kilometres (acres)	The land required for cooling towers or ponds, including support facilities such as equipment sheds, basins, canals, or shoreline buffer areas	maximum	yes
2.7.2 Height	m (ft)	The vertical height above finished grade of hybrid cooling towers associated with the cooling water systems	maximum	no
3. Ultimate Heat Sink				
3.1 Ambient Air Requirements				
3.1.1 Maximum Ambient Temperature (0% Exceedance)	°C (°F)	Assumption used for the maximum ambient temperature in designing the Ultimate Heat Sink (UHS) system to provide heat rejection for 30 days under the assumed temperature condition	minimum	no
3.1.2 Maximum Wet Bulb Temperature (0% Exceedance)	°C (°F)	Assumption used for the maximum wet bulb temperature in designing the UHS system to provide heat rejection for 30 days under the assumed temperature condition	minimum	no

Report

OPG Proprietary		
Document Number: N-REP-01200-10000	Usage Classification: N/A	
Sheet Number: N/A	Revision Number: R006	Page: Page 31 of 147

Title: **Use of Plant Parameters Envelope to Encompass the Reactor Designs being considered for the Darlington Site**

PPE Parameter	Units	Definition	Characteristic of Limiting Parameter Value	Parameter Value to be Prorated Based on Number of Units on Site?
3.1.3 Minimum Ambient Temperature (0% Exceedance)	°C (°F)	Assumption used for the minimum ambient temperature in designing the UHS system to provide heat rejection for 30 days under the assumed temperature condition	maximum	no
3.2 UHS Heat Exchanger				
3.2.1 Maximum Inlet Temp to UHS Heat Exchanger	°C (°F)	The maximum temperature of safety-related service water at the inlet of the UHS component cooling water heat exchanger	minimum	no
3.2.2 UHS Heat Exchanger Duty	watts (BTU per hour)	The heat transferred to the safety-related service water system for rejection to the environment in UHS heat removal devices.	maximum	yes
3.3 Mechanical Draft Cooling Towers				
3.3.1 Acreage	square kilometres (acres)	The land required for cooling towers or ponds, including support facilities such as equipment sheds, basins, canals, or shoreline buffer areas	maximum	yes
3.3.2 Approach Temperature	°C (°F)	The difference between the cold water temperature and the ambient wet bulb temperature.	minimum	no
3.3.3 Blowdown Constituents and Concentrations	parts per million	The maximum expected concentrations for anticipated constituents in the cooling water systems blowdown to the receiving water body	maximum	no
3.3.4 Blowdown Flow Rate	litres per second (gallons per minute)	The normal (and maximum) flow rate of the blowdown stream from the cooling water systems to the receiving water body for closed system designs	maximum	yes

Report

OPG Proprietary		
Document Number: N-REP-01200-10000		Usage Classification: N/A
Sheet Number: N/A	Revision Number: R006	Page: Page 32 of 147

Title:
Use of Plant Parameters Envelope to Encompass the Reactor Designs being considered for the Darlington Site

PPE Parameter	Units	Definition	Characteristic of Limiting Parameter Value	Parameter Value to be Prorated Based on Number of Units on Site?
3.3.5 Blowdown Temperature	°C (°F)	The maximum expected blowdown temperature at the point of discharge to the receiving water body	maximum	no
3.3.6 Cycles of Concentration	number	The ratio of total dissolved solids in the cooling water blowdown streams to the total dissolved solids in the makeup water streams	maximum	no
3.3.7 Evaporation Rate	litres per second (gallons per minute)	The expected (and maximum) rate at which water is lost by evaporation from the cooling water systems	maximum	yes
3.3.8 Height	m (ft)	The vertical height above finished grade of mechanical draft cooling towers associated with the cooling water systems	maximum	no
3.3.9 Makeup Flow Rate	litres per second (gallons per minute)	The expected (and maximum) rate of removal of water from a natural source to replace water losses from closed cooling water systems	maximum	yes
3.3.10 Noise	decibels	The maximum expected sound level produced by operation of cooling towers, measured at 1000 feet from the noise source	maximum	no
3.3.11 Cooling Tower Temperature Range	°C (°F)	The temperature difference between the cooling water entering and leaving the towers	minimum	no
3.3.12 Cooling Water Flow Rate	litres per second (gallons per minute)	The total cooling water flow rate through the condenser / heat exchangers	maximum	yes

Report

OPG Proprietary		
Document Number: N-REP-01200-10000		Usage Classification: N/A
Sheet Number: N/A	Revision Number: R006	Page: Page 33 of 147

Title:
Use of Plant Parameters Envelope to Encompass the Reactor Designs being considered for the Darlington Site

PPE Parameter	Units	Definition	Characteristic of Limiting Parameter Value	Parameter Value to be Prorated Based on Number of Units on Site?
3.3.13 Heat Rejection Rate (blowdown)	litres per second @ °C (gallons per minute @ °F)	The expected heat rejection rate to a receiving water body, expressed as flow rate in litres per second at a temperature in degrees celsius	maximum	yes
3.3.14 Maximum Consumption of Raw Water	litres per second (gallons per minute)	The expected maximum short-term consumptive use of water by the cooling water systems (evaporation and drift losses)	maximum	yes
3.3.15 Monthly Average Consumption of Raw Water	litres per second (gallons per minute)	The expected normal operating consumption of water by the cooling water systems (evaporation and drift losses)	maximum	yes
3.3.16 Stored Water Volume	litres (gallons)	The quantity of water stored in cooling water system impoundments, basins, tanks and/or ponds	maximum	yes
3.4 Once-Through Cooling				
3.4.1 Cooling Water Discharge Temperature	°C (°F)	Expected temperature of the cooling water at the exit of the UHS system	maximum	no
3.4.2 Cooling Water Flow Rate	litres per second (gallons per minute)	Total cooling water flow rate through the UHS (also the rate of withdrawal from and return to the water source)	maximum	yes
3.4.3 Cooling Water Temperature Rise	°C (°F)	Temperature rise across the heat exchangers cooled by the UHS (temperature of water out minus temperature of water in)	maximum	no
3.4.4 Minimum Essential Flow Rate	litres per second		maximum	yes

Report

OPG Proprietary		
Document Number: N-REP-01200-10000		Usage Classification: N/A
Sheet Number: N/A	Revision Number: R006	Page: Page 34 of 147

Title: **Use of Plant Parameters Envelope to Encompass the Reactor Designs being considered for the Darlington Site**

PPE Parameter	Units	Definition	Characteristic of Limiting Parameter Value	Parameter Value to be Prorated Based on Number of Units on Site?
	(gallons per minute)	Minimum flow required to maintain required heat removal capacity under design-basis accident conditions		
3.4.5 Evaporation Rate	litres per second (gallons per minute)	The expected (and maximum) rate at which water is lost by evaporation from the UHS as a result of heat rejection from the plant	maximum	yes
3.4.6 Heat Rejection Rate	watts (BTU per hour)	The expected heat rejection rate to the UHS	maximum	yes
<u>4. Containment Heat Removal System (Post-Accident)</u>				
<u>4.1 Ambient Air Requirements</u>				
4.1.1 Maximum Ambient Air Temperature (0% Exceedance)	°C (°F)	Assumed maximum ambient temperature used in designing the containment heat removal system	minimum	no
4.1.2 Minimum Ambient Temperature (0% Exceedance)	°C (°F)	Assumed minimum ambient temperature used in designing the containment heat removal system	maximum	no
<u>5. Potable Water/Sanitary Waste System</u>				
<u>5.1 Discharge to Site Water Bodies</u>				
5.1.1 Flow Rate	litres per second (gallons per minute)	The expected (and maximum) effluent flow rate from the potable and sanitary waste water systems to the receiving water body	maximum	yes

Report

OPG Proprietary		
Document Number: N-REP-01200-10000		Usage Classification: N/A
Sheet Number: N/A	Revision Number: R006	Page: Page 35 of 147

Title: **Use of Plant Parameters Envelope to Encompass the Reactor Designs being considered for the Darlington Site**

PPE Parameter	Units	Definition	Characteristic of Limiting Parameter Value	Parameter Value to be Prorated Based on Number of Units on Site?
5.2 Raw Water Requirements				
5.2.1 Maximum Use	litres per second (gallons per minute)	The maximum short-term rate of withdrawal from the water source for the potable and sanitary waste water systems	maximum	yes
5.2.2 Monthly Average Use	litres per second (gallons per minute)	The average rate of withdrawal from the water source for the potable and sanitary waste water systems	maximum	yes
6. Demineralized Water System				
6.1 Discharge to Site Water Bodies				
6.1.1 Flow Rate	litres per second (gallons per minute)	The expected (and maximum) effluent flow rate from the demineralized system to the receiving water body	maximum	yes
6.2 Raw Water Requirements				
6.2.1 Maximum Use	litres per second (gallons per minute)	The maximum short-term rate of withdrawal from the water source for the demineralized water system.	maximum	yes
6.2.2 Monthly Average Use	litres per second (gallons per minute)	The average rate of withdrawal from the water source for the demineralized water system	maximum	yes

Report

OPG Proprietary		
Document Number: N-REP-01200-10000		Usage Classification: N/A
Sheet Number: N/A	Revision Number: R006	Page: Page 36 of 147

Title:
Use of Plant Parameters Envelope to Encompass the Reactor Designs being considered for the Darlington Site

PPE Parameter	Units	Definition	Characteristic of Limiting Parameter Value	Parameter Value to be Prorated Based on Number of Units on Site?
<u>7. Fire Protection System</u>				
7.1 Raw Water Requirements				
7.1.1 Maximum Use	litres per second (gallons per minute)	The maximum short-term rate of withdrawal from the water source for the fire protection water system.	maximum	yes
7.1.2 Monthly Average Use	litres per second (gallons per minute)	The average rate of withdrawal from the water source for the fire protection water system	maximum	yes
7.1.3 Stored Water Volume	litres (gallons)	The quantity of water stored in fire protection system impoundments, basins or tanks	maximum	yes
<u>8. Miscellaneous Drain</u>				
8.1 Discharge to Site Water Bodies				
8.1.1 Flow Rate	litres per second (gallons per minute)	The expected (and maximum) effluent flow rate from miscellaneous drains to the receiving water body	maximum	yes
<u>9. Airborne Effluent Release</u>				
9.1 Atmospheric Dispersion (CHI/Q) (Accident)				
9.1.1 Exclusion Area Boundary (EAB)	radius in km	Radius of the exclusion area boundary assumed in dose calculations	maximum	no

Report

OPG Proprietary		
Document Number: N-REP-01200-10000		Usage Classification: N/A
Sheet Number: N/A	Revision Number: R006	Page: Page 37 of 147

Title:
Use of Plant Parameters Envelope to Encompass the Reactor Designs being considered for the Darlington Site

PPE Parameter	Units	Definition	Characteristic of Limiting Parameter Value	Parameter Value to be Prorated Based on Number of Units on Site?
9.1.2 Low Population Zone boundary (LPZ)	radius in km	Radius of the low population zone boundary assumed in dose calculations	maximum	no
9.1.3 0-2 hr @ EAB	seconds per metre cubed	The atmospheric dispersion coefficients used in the design safety analysis to estimate dose consequences of ambient airborne releases	maximum	no
9.1.4 0-8 hr @ LPZ			maximum	no
9.1.5 8-24 hr @ LPZ			maximum	no
9.1.6 1-4 day @ LPZ			maximum	no
9.1.7 4-30 day @ LPZ			maximum	no
9.2 Atmospheric Dispersion (CHI/Q) (Annual Average)	seconds per metre cubed	The atmospheric dispersion coefficients used in the safety analysis for the dose consequences of normal airborne releases	maximum	no
9.3 Dose Consequences				
9.3.1 Normal	sieverts (rem)	The estimated design radiological dose consequences due to gaseous releases from normal operation of plant	maximum	yes
9.3.2 Normal, limiting	sieverts (rem)	The limiting (i.e., worst case) radiological dose consequences due to gaseous releases from normal operation of plant	maximum	yes
9.3.3 Design Basis Accident	sieverts (rem)	The limiting (i.e., worst case) radiological dose consequences due to gaseous releases from postulated accidents	maximum	no
9.3.4 Severe Accidents (Beyond Design Basis Accidents)	sieverts (rem)	The limiting (i.e., worst case) radiological dose consequences due to gaseous releases from severe accidents	maximum	no

Report

OPG Proprietary		
Document Number: N-REP-01200-10000		Usage Classification: N/A
Sheet Number: N/A	Revision Number: R006	Page: Page 38 of 147

Title: **Use of Plant Parameters Envelope to Encompass the Reactor Designs being considered for the Darlington Site**

PPE Parameter	Units	Definition	Characteristic of Limiting Parameter Value	Parameter Value to be Prorated Based on Number of Units on Site?
9.4 Release Point				
9.4.1 Configuration	horizontal or vertical	The orientation of the release point discharge flow	horizontal	no
9.4.2 Elevation (Normal Operation)	m (ft)	The elevation above finished grade of the release point for routine operational releases	minimum	no
9.4.3 Elevation (Design Basis Accident)	m (ft)	The elevation above finished grade of the release point for accident sequence releases	minimum	no
9.4.4 Minimum Distance to Site Boundary	m (ft)	The minimum lateral distance from the release point to the site boundary	maximum	no
9.4.5 Temperature	°C (°F)	The temperature of the airborne effluent stream at the release point	maximum	no
9.4.6 Volumetric Flow Rate	litres per second (standard cubic feet per minute)	The volumetric flow rate of the airborne effluent stream at the release point	maximum	no
9.5 Source Term				
9.5.1 Gaseous (Normal)	becquerels per year (curies per year)	The annual activity, by isotope, contained in routine plant airborne effluent streams	maximum	yes
9.5.2 Gaseous (Design Basis Accident)	becquerels (curies)	The activity, by isotope, contained in postaccident airborne effluents.	maximum	no
9.5.3 Tritium	becquerels per year (curies per year)	The annual activity of tritium contained in routine plant airborne effluent streams	maximum	yes
10. Liquid Radwaste System				

Report

OPG Proprietary		
Document Number: N-REP-01200-10000	Usage Classification: N/A	
Sheet Number: N/A	Revision Number: R006	Page: Page 39 of 147

Title:
Use of Plant Parameters Envelope to Encompass the Reactor Designs being considered for the Darlington Site

PPE Parameter	Units	Definition	Characteristic of Limiting Parameter Value	Parameter Value to be Prorated Based on Number of Units on Site?
10.1 Dose Consequences				
10.1.1 Normal	sieverts (rem)	The design radiological dose consequences due to liquid effluent releases from normal operation of the plant	maximum	yes
10.1.2 Design Basis Accident	sieverts (rem)	The design radiological dose consequences due to liquid effluent releases from postulated accidents	maximum	no
10.2 Release Point				
10.2.1 Flow Rate	litres per second (gallons per minute)	The discharge (including minimum dilution flow, if any) of liquid potentially radioactive effluent streams from plant systems to the receiving water body	maximum	yes
10.3 Source Term				
10.3.1 Liquid	becquerels per year (curies per year)	The annual activity, by isotope, contained in routine plant liquid effluent streams	maximum	yes
10.3.2 Tritium	becquerels per year (curies per year)	The annual activity of tritium contained in routine plant liquid effluent streams	maximum	yes
11. Solid Radwaste System				
11.1 Acreage				
11.1.1 Low Level Radwaste Storage	square kilometres (acres)	The land usage required to provide onsite storage of low level radioactive wastes	maximum	yes
11.2 Solid Radwaste				

Report

OPG Proprietary		
Document Number: N-REP-01200-10000		Usage Classification: N/A
Sheet Number: N/A	Revision Number: R006	Page: Page 40 of 147

Title:
Use of Plant Parameters Envelope to Encompass the Reactor Designs being considered for the Darlington Site

PPE Parameter	Units	Definition	Characteristic of Limiting Parameter Value	Parameter Value to be Prorated Based on Number of Units on Site?
11.2.1 Activity	becquerels per year (curies per year)	The annual activity, by isotope, contained in solid radioactive wastes generated during routine plant operations	maximum	yes
11.2.3 Volume	cubic metres per year (cubic feet per year)	The expected volume of solid radioactive wastes generated during routine plant operations	maximum	yes
12. Fuel				
12.1 Fuel Design				
12.1.1 Fuel enrichment	%U-235 in total U	The enrichment of the fuel	maximum	no
12.1.2 Mass of fuel in core	Mg (Tons)	The total mass of uranium dioxide in the core	maximum	yes
12.1.3 Mass of Zirconium alloys in core	Mg (Tons)	The total mass of all zirconium alloys in the core	maximum	yes
12.2 Discharged Fuel				
12.2.1 Total mass	Mg (tons)	Total mass of fuel used during the lifetime of the reactor	maximum	yes
12.3 Spent Fuel Storage Pool				
12.3.1 Pool capacity	years	Number of years of reactor operation that spent fuel storage pool can accommodate all fuel discharged from the core	minimum	no
12.3.2 Pool volume	cubic metres (cubic feet)	Volume of spent fuel storage pool	maximum	yes

Report

OPG Proprietary		
Document Number: N-REP-01200-10000		Usage Classification: N/A
Sheet Number: N/A	Revision Number: R006	Page: Page 41 of 147

Title: **Use of Plant Parameters Envelope to Encompass the Reactor Designs being considered for the Darlington Site**

PPE Parameter	Units	Definition	Characteristic of Limiting Parameter Value	Parameter Value to be Prorated Based on Number of Units on Site?
12.3.3 Annual dose	sieverts (rem)	Annual dose at the EAB due to operation of the spent fuel storage pool	maximum	yes
12.4 Spent Fuel Dry Storage				
12.4.1 Acreage	square kilometres (acres)	The land usage required to provide onsite dry storage of spent fuel for the expected plant lifetime, including the fenced off area necessary to provide an acceptable radiation protection and security zone	maximum	yes
12.4.2 Storage Capacity	years	The years of plant operation for which spent fuel dry storage should be provided without taking credit for capacity in the spent fuel pool	maximum	no
12.4.3 Annual dose	sieverts (rem)	Annual dose at the EAB due to operation of the spent fuel dry storage area	maximum	no
13. Auxiliary Boiler Systems				
13.1 Exhaust Elevation	m (ft)	The height above finished plant grade at which the flue gas effluents are released to the environment	minimum	no
13.2 Flue Gas Effluents	kg per year (pounds per year)	The expected combustion products and anticipated quantities released to the environment due to operation of the auxiliary boilers and diesel engines	maximum	yes
13.3 Fuel Type	N/A	The type of fuel oil required for proper operation of the auxiliary boilers and diesel engines	N/A	no
13.4 Heat Input Rate	watts (BTU per hour)	The average heat input rate due to the periodic operation of the auxiliary boilers	maximum	yes

Report

OPG Proprietary		
Document Number: N-REP-01200-10000		Usage Classification: N/A
Sheet Number: N/A	Revision Number: R006	Page: Page 42 of 147

Title: **Use of Plant Parameters Envelope to Encompass the Reactor Designs being considered for the Darlington Site**

PPE Parameter	Units	Definition	Characteristic of Limiting Parameter Value	Parameter Value to be Prorated Based on Number of Units on Site?
<u>14. Heating, Ventilation and Air Conditioning System (HVAC)</u>				
14.1 Ambient Air Requirements				
14.1.1 Non-safety HVAC Max Ambient Temp (1% Exceedance)	°C (°F)	Assumption used for the maximum ambient temperature that will be exceeded no more than 1% of the time, to design the non-safety HVAC systems	minimum	no
14.1.2 Non-safety HVAC Min Ambient Temp (1% Exceedance)	°C (°F)	Assumption used for the minimum ambient temperature that will be exceeded no more than 1% of the time, to design the non-safety HVAC systems	maximum	no
14.1.3 Safety HVAC Max Ambient Temp (0% Exceedance)	°C (°F)	Assumption used for the maximum ambient temperature that will never be exceeded, to design the safety-related HVAC systems	minimum	no
14.1.4 Safety HVAC Min Ambient Temp (0% Exceedance)	°C (°F)	Assumption used for the minimum ambient temperature that will never be exceeded, to design the safety-related HVAC systems	maximum	no
14.1.5 Vent System Max Ambient Temp (5% Exceedance)	°C (°F)	Assumption used for the maximum ambient temperature that will be exceeded no more than 5% of the time to design the non-HVAC ventilation systems	minimum	no
14.1.6 Vent System Min Ambient Temp (5% Exceedance)	°C (°F)	Assumption used for the minimum ambient temperature that will be exceeded no more than 5% of the time to design the non-HVAC ventilation systems	maximum	no

Report

OPG Proprietary		
Document Number: N-REP-01200-10000		Usage Classification: N/A
Sheet Number: N/A	Revision Number: R006	Page: Page 43 of 147

Title:
Use of Plant Parameters Envelope to Encompass the Reactor Designs being considered for the Darlington Site

PPE Parameter	Units	Definition	Characteristic of Limiting Parameter Value	Parameter Value to be Prorated Based on Number of Units on Site?
<u>15. Onsite/Offsite Electrical Power System</u>				
<u>15.1 Acreage</u>				
15.1.1 Switchyard	square kilometres (acres)	The land usage required for the high voltage switchyard used to connect the plant to the transmission grid	maximum	yes
<u>16. Standby Power</u>				
<u>16.1 Diesel</u>				
16.1.1 Diesel Capacity	kilowatts	The capacity of diesel engines used for generation of standby electrical power	maximum	yes
16.1.2 Diesel Exhaust Elevation	m (ft)	The elevation above finished grade of the release point for standby diesel exhaust releases	minimum	no
16.1.3 Diesel Flue Gas Effluents	kg per year (pounds per year)	The expected combustion products and anticipated quantities released to the environment due to operation of the emergency standby diesel generators	maximum	yes
16.1.4 Diesel Noise	decibels	The maximum expected sound level produced by operation of diesel engines turbines, measured at 50 feet from the noise source	maximum	no
16.1.5 Diesel Fuel Type	N/A	The type of fuel oil required for proper operation of the diesel engines	N/A	no
<u>17. Plant Characteristics</u>				
<u>17.1 Access Routes</u>				
17.1.1 Heavy Haul Routes	square kilometres (acres)	The land usage required for permanent heavy haul routes to support normal operations and refuelling	maximum	no

Report

OPG Proprietary		
Document Number: N-REP-01200-10000		Usage Classification: N/A
Sheet Number: N/A	Revision Number: R006	Page: Page 44 of 147

Title: **Use of Plant Parameters Envelope to Encompass the Reactor Designs being considered for the Darlington Site**

PPE Parameter	Units	Definition	Characteristic of Limiting Parameter Value	Parameter Value to be Prorated Based on Number of Units on Site?
17.1.2 Spent Fuel Cask Weight	Mg (tons)	The weight of the heaviest expected shipment during normal plant operations and refuelling	maximum	no
17.2 Acreage	square kilometres (acres)	The land area required to provide space for plant facilities		
17.2.1 Office Facilities			maximum	Note 1
17.2.2 Parking Lots			maximum	Note 1
17.2.3 Permanent Support Facilities			maximum	Note 1
17.2.4 Power Block			maximum	yes
17.2.5 Protected Area			maximum	Note 1
17.3 Plant Population				
17.3.1 Operation	persons	The number of people required to operate and maintain the plant	maximum	Note 1
17.3.2 Refuelling / Major Maintenance	persons	The additional number of temporary staff required to conduct refuelling and major maintenance activities	maximum	no
18. Construction				
18.1 Access Routes				
18.1.1 Construction Module Dimensions	m (ft)	The maximum expected length, width, and height of the largest construction modules or components and delivery vehicles to be transported to the site during construction	maximum	no
18.1.2 Heaviest Construction Shipment	Mg (tons)	The maximum expected weight of the heaviest construction shipment to the site	maximum	no
18.2 Acreage				

Report

OPG Proprietary		
Document Number: N-REP-01200-10000		Usage Classification: N/A
Sheet Number: N/A	Revision Number: R006	Page: Page 45 of 147

Title: **Use of Plant Parameters Envelope to Encompass the Reactor Designs being considered for the Darlington Site**

PPE Parameter	Units	Definition	Characteristic of Limiting Parameter Value	Parameter Value to be Prorated Based on Number of Units on Site?
18.2.1 Laydown Area	square kilometres (acres)	The land area required to provide space for construction support facilities	maximum	Note 1
18.2.2 Temporary Construction Facilities	square kilometres (acres)		maximum	Note 1
18.3 Construction Noise	decibels	The maximum expected sound level due to construction activities, measured at 50 feet from the noise source	maximum	no
18.4 Plant Construction Population	persons	Peak employment during plant construction	maximum	Note 1
18.5 Site Preparation Duration	months	Length of time required to prepare the site for construction	maximum	no
<u>19</u> Decommissioning				
19.1 Access Routes				
19.1.1 Decommissioning Dimensions	m (ft)	The maximum expected length, width, and height of the largest components and delivery vehicles to be transported on or off-site during decommissioning	maximum	no
19.1.2 Heaviest Decommissioning Shipment	Mg (tons)	The maximum expected weight of the heaviest shipment on or off the site during decommissioning	maximum	no
19.2 Acreage				
19.2.1 Laydown Area	square kilometres (acres)	The land area required to provide space for decommissioning support facilities	maximum	no
19.2.2 Temporary Decommissioning Facilities	square kilometres (acres)		maximum	no

Report

OPG Proprietary		
Document Number: N-REP-01200-10000		Usage Classification: N/A
Sheet Number: N/A	Revision Number: R006	Page: Page 46 of 147

Title:
Use of Plant Parameters Envelope to Encompass the Reactor Designs being considered for the Darlington Site

PPE Parameter	Units	Definition	Characteristic of Limiting Parameter Value	Parameter Value to be Prorated Based on Number of Units on Site?
19.3 Decommissioning Noise	decibels	The maximum expected sound level due to decommissioning activities, measured at 50 feet from the noise source	maximum	no
19.4 Plant Decommissioning Population	persons	Peak employment during plant decommissioning	maximum	yes
19.5 Site Preparation Duration	months	Length of time required to prepare the site for decommissioning	maximum	no
19.6 Delay time prior to decommissioning	months	Length of time required to allow radiation fields to decrease prior to commencing decommissioning	maximum	no
19.7 Mass of Plant Material and Components				
19.7.1 Mass of Highly Active Material	Mg (tons)	Total mass of plant components and materials that are highly active and require specially shielded handling techniques during, and/or significant time delays prior to, decommissioning	maximum	yes
19.7.2 Mass of Moderately Active Material	Mg (tons)	Total mass of plant components and materials that are moderately active and require some shielded handling techniques during, and/or some time delays prior to, decommissioning	maximum	yes
19.7.3 Mass of Low Activity Material	Mg (tons)	Total mass of plant components and materials that are slightly active but require no shielded handling techniques during, and/or no time delays prior to, decommissioning	maximum	yes
19.7.4 Mass of on-Active Material	Mg (tons)	Total mass of plant components and materials that are not active but must be transported and/or handled during decommissioning	maximum	yes

Report

OPG Proprietary		
Document Number: N-REP-01200-10000		Usage Classification: N/A
Sheet Number: N/A	Revision Number: R006	Page: Page 47 of 147

Title:
Use of Plant Parameters Envelope to Encompass the Reactor Designs being considered for the Darlington Site

PPE Parameter	Units	Definition	Characteristic of Limiting Parameter Value	Parameter Value to be Prorated Based on Number of Units on Site?
19.8 Decommissioning materials				
19.8.1 Concrete	Mg (tons)	Total mass of concrete to be used in decommissioning	maximum	yes
19.8.2 Land fill	Mg (tons)	Total mass of landfill to be used in decommissioning	maximum	yes

Note 1: Prorated parameter value for multiple units on site will be greater than the single unit value but not greater by number of units on site

Report

OPG Proprietary		
Document Number: N-REP-01200-10000		Usage Classification: N/A
Sheet Number: N/A	Revision Number: R006	Page: Page 48 of 147

Title:
Use of Plant Parameters Envelope to Encompass the Reactor Designs being considered for the Darlington Site

B.1.2 Table 2. Summary of Reactors under Consideration

Table 2: PPE Parameter Characteristics

Reactor Design	Gross Power MWe	House Load MWe	Net Power MWe	Number of Units on Site
Pressurized Water Reactors (PWRs)				
EPR	1708	128	1580	3
AP-1000	1117	80 (est)	1037 (est)	4
Pressurized Hybrid Reactor (PHR)				
ACR-1000	1165	80	1085	4
Pressurized Heavy Water Reactor (PHWR)				
EC6	740	54	686	4
Boiling Water Reactor (BWRs)				
BWRX-300	318 (est)	18 (est)	300	4

Report

OPG Proprietary		
Document Number: N-REP-01200-10000	Usage Classification: N/A	
Sheet Number: N/A	Revision Number: R006	Page: Page 49 of 147
Title: Use of Plant Parameters Envelope to Encompass the Reactor Designs being considered for the Darlington Site		

B.1.3

Table 3. Site Parameters and Darlington Characteristic Values, Composite Table

Table 3: Site Parameters and Darlington Characteristic Values, Composite Table

PPE Parameter		Definition	PPE Limiting Value	Limiting Reactor	Darlington Site Characteristic Value	Comments	Bounded by PPE Value?
1 Structure							
1.2 Precipitation (for Roof Design)							
1.2.1	Maximum Rainfall Rate	The Probable Maximum Precipitation (PMP) value that can be accommodated by a plant design. Expressed as maximum precipitation for 1 hour in 1 square km and as maximum precipitation for 5 minutes in 1 square km	400 mm/d 100 mm/h 30 mm/15 min	EC6, ACR-1000	210 mm/d Regional Storm (roof loading) 40.1 mm/h 30-year peak hourly rainfall 10 mm/15 min (pro-rated 30-year peak hourly rainfall - roof drainage)	The 210 mm/d Regional Storm value for roof loading approximates the rainfall from Hurricane Hazel (1956) and is conservative because a value of 88.6 mm/d for 100-year rainfall would also apply to the site and be relevant for roof loading. The value of 40.1 mm/h is a 30-year peak hourly rainfall, not a Probable Maximum Precipitation (PMP) which has different definitions for Ontario and the US NRC. The value of 10 mm/15 min is simply pro-rated from the 30-year peak hourly rainfall and can be used in relation to sizing of roof drainage. The numbers presented are relevant for roof design only.	Yes
1.2.2	Snow & Ice Load	The maximum load on structure roofs due to the accumulation of snow and ice that can be accommodated by a plant design	3.0 kPa	EC6	2.2 kPa	The National Building Code of Canada provides the methodology to calculate the snow load on the roof. The calculation is related to various parameters such as roof shape, slope and wind exposure and hence depends on details of the actual design. Although the ground snow load and the associated rain load is provided in the National Building Code of Canada for Bowmanville, Ontario, the ground snow load has to be multiplied by four other factors to calculate the load on structure roofs. The Darlington site characteristic value is an estimate without details of the roof design.	Yes
1.3 Design Basis Earthquake (DBE)							
1.3.1	Design Response Spectra	The assumed design response spectra used to establish a plant's seismic design	Canadian Regulatory Approach to site design basis earthquake	EPR, EC6, AP1000, ACR-1000	See Table 3.1	The table of values is the Uniform Hazard Response Spectrum (UHRS) for the Darlington site, and is drawn from Table 5.4 in the Probabilistic Seismic Hazard Assessment report (NK054-REP-01210-00014R001**). The UHRS is shown graphically in the Nuclear Safety Considerations report (NK054-REP01210-00008-R001**) on pages 47 and 48. The UHRS values are at the top of the reactor building for 10-4 /y probability of exceedance. For a frequency of 100 Hz, the mean hazard horizontal acceleration of 0.209 g for the top of the building is the same as for the bottom of the foundation, which is at the top of bedrock, 14 m below the ground surface, and is the Peak Ground Acceleration (PGA). Some other UHRS mean hazard horizontal accelerations are greater than 0.209 g because the building amplifies the ground motion input. The vendor Certified Seismic Design Response Spectra (CSDRS) for the technologies, shown in comparison to the UHRS in the figure on page 48, can accommodate the UHRS.	Yes

Report

OPG Proprietary		
Document Number: N-REP-01200-10000	Usage Classification: N/A	
Sheet Number: N/A	Revision Number: R006	Page: Page 50 of 147

Title: Use of Plant Parameters Envelope to Encompass the Reactor Designs being considered for the Darlington Site

PPE Parameter	Definition	PPE Limiting Value	Limiting Reactor	Darlington Site Characteristic Value	Comments	Bounded by PPE Value?	
1.3.2	Design Peak Ground Acceleration	The maximum earthquake ground acceleration for which a plant is designed, this is defined as the acceleration which corresponds to the zero period in the response spectra taken in the free field at plant grade elevation	0.3 g	EPR, EC6, AP1000, ACR-1000	See Table 3.2	These accelerations in gravities are at the top of the sedimentary rock (power block foundation, 14 m below existing grade) for 10-4 annual exceedance frequency. These are values for the 100 Hz line of Table 5.4 in the Probabilistic Seismic Hazard Assessment (NK054-REP-01210-00014-R001**). The Design Peak Ground Acceleration value is placed at a spectral frequency above which there is little energy in the ground motions. For eastern North America, this occurs at about 100 Hz and therefore the table only shows the 100 Hz values. This is the frequency above which earthquake ground motions no longer contain significant energy, and correspondingly, the frequency at which the peak spectral acceleration of the structure (e.g. the top of the reactor building) is equal to the peak acceleration of the input (the earthquake). This is conventional for probabilistic seismic hazard assessments.	Yes
1.3.3	Time History	The plot of earthquake ground motion as a function of time used to establish a plant's seismic design	Canadian Regulatory Approach to site design basis earthquake	EPR, EC6, AP1000, ACR-1000	To be determined during the design phase of the project.	In line with guidance of International Atomic Energy Agency Seismic Design and Qualification of Nuclear Plants (NS-G-1.6), the standard industry practice for the construction of new nuclear power plants is to develop the Design Basis Earthquake (DBE) time history during the design phase if needed for specific tasks, such as site-specific soil structure interaction (SSI) analyses or site-specific design of various facilities.	Yes (to be confirmed)
1.3.4	Capable Tectonic Structures or Sources	The assumption made in a plant design about the presence of capable faults or earthquake sources in the vicinity of the plant site (e.g., No fault displacement potential within the investigative area)	No fault displacement within the site area	EPR, EC6, AP1000, ACR-1000	No capable faults in site area	It was concluded in Section 7.0 of the Summary of Seismic Hazard Evaluations report (NK054-REP01210-00015-R001**) that there are no nearby capable faults.	Yes
1.4 Site Water Level (Allowable)							
1.4.1	Maximum Flood (or Tsunami)	Design assumption regarding the difference in elevation between finished plant grade and the water level due to the probable maximum flood (or Tsunami)	0.341 m (1 ft) below grade	EPR	0.341 m below Plant Grade Elevation (PGE).	For detailed information, refer to pages 54 and 84 of report Evaluation of Geotechnical Aspects (NK054-REP-01210-00011-R001**). This is a design assumption, rather than a site characteristic.	Yes
1.4.2	Maximum Ground Water	Design assumption regarding the difference in elevation between finished plant grade and the maximum site ground water level used in the plant design	-1 m (-3.3 ft) from plant grade	EPR, EC6	1 m below Plant Grade Elevation (PGE).	For detailed information, refer to Pages 54, 65, and 84 of report Evaluation of Geotechnical Aspects (NK054-REP-01210-00011-R001**). This is a design assumption, rather than a site characteristic.	Yes
1.5 Soil Properties Design Bases							
1.5.1	Liquefaction	Design assumption regarding the presence of potentially liquefying soils at a site	No liquefaction is permitted at the site	EPR, EC6, AP1000, ACR-1000	No liquefaction at this site	Refer to pages 84, 86-87, 180 of report Evaluation of Geotechnical Aspects (NK054-REP-01210-00011R001**).	Yes

Report

OPG Proprietary		
Document Number: N-REP-01200-10000	Usage Classification: N/A	
Sheet Number: N/A	Revision Number: R006	Page: Page 51 of 147

Title:
Use of Plant Parameters Envelope to Encompass the Reactor Designs being considered for the Darlington Site

PPE Parameter		Definition	PPE Limiting Value	Limiting Reactor	Darlington Site Characteristic Value	Comments	Bounded by PPE Value?
1.5.2	Minimum Required Bearing Capacity (Static)	Design assumption regarding the capacity of the competent loadbearing layer required to support the loads exerted by plant structures used in the plant design	718 kPa (15 ksf)	EPR, EC6	1000 to 2000 kPa	This value (1000 to 2000 kPa) is for bedrock. For details, refer to Page 63 of report Evaluation of Geotechnical Aspects (NK054-REP-01210-00011-R001**).	Yes
1.5.3	Minimum Shear Wave Velocity	The assumed limiting propagation velocity of shear waves through the foundation materials used in the plant design	304.8 m/s(1000 fps)	AP1000, EC6	1600 m/s	The limiting shear wave velocity, among the reactor designs under consideration, for a reactor to be able to be built on, was 304.8 m/s. The bedrock to be used for the power block foundation has a shear wave velocity many times greater than this. The deep layers had estimated velocities of 1825 m/s and 1586 m/s (Table 4.2 of Probabilistic Seismic Hazard Assessment, NK054-REP-01210-00014-R001**), therefore the minimum shear wave velocity can be estimated as approximately 1600 m/s.	Yes
1.6 Design Basis Tornado							
1.6.1	Maximum Pressure Drop	The design assumption for the decrease in ambient pressure from normal atmospheric pressure due to the passage of the tornado	8.274 kPa (1.2 psi)	EPR	6.3 kPa (0.9 psi)	<p>This value was based on the US NRC Regulatory Guide 1.76 Rev1 entitled "Design-Basis Tornado and Tornado Missiles for Nuclear Power Plants", March 2007.</p> <p>6.3 kPa (0.9 psi) is for a tornado with a maximum wind speed of 321.8 km/h (200 mph) which is the upper limit for an Enhanced Fujita scale 4 (EF-4) tornado, which causes the same level of damage as a Fujita scale 4 (F-4) tornado. See the "Comments" for Parameter 1.6.4. The pressure drop is calculated as the density of the air (1.226 kg/m³) times the maximum rotational speed (Parameter 1.6.2, 257.4 km/h, expressed as 72 m/s) squared (per US NRC RG-1.76 Rev1, page 5, formula 2).</p> <p>Note that the value is assumed to be characteristic of the Darlington site and is conservative because the maximum wind speed that is used, 321.8 km/h (parameter 1.6.4), is the upper limit of an EF-4 category tornado, and the value is not a measured value for the Darlington site.</p>	Yes
1.6.2	Maximum Rotational Speed	The design assumption for the component of tornado wind speed due to the rotation within the tornado	296 km/h (184 mph)	EPR	257.4 km/h (160 mph)	<p>This value was based on the US NRC Regulatory Guide 1.76 Rev1 entitled "Design-Basis Tornado and Tornado Missiles for Nuclear Power Plants", March 2007.</p> <p>Calculated as the difference between the maximum tornado wind speed (PPE Parameter 1.6.4) and the tornado translational speed (PPE Parameter 1.6.3) (per US NRC RG-1.76 Rev1, page 5, last paragraph).</p> <p>Note that the value is assumed to be characteristic of the Darlington site and is conservative because maximum wind speed is taken as the upper limit of an EF-4 category tornado, and the value is not a measured value for the Darlington site.</p>	Yes
1.6.3	Maximum Translational Speed	The design assumption for the component of tornado wind speed due to the movement of the tornado over the ground	74 km/h (46 mph)	EPR	64.4 km/h (40 mph)	<p>This value was based on the US NRC Regulatory Guide 1.76 Rev1 entitled "Design-Basis Tornado and Tornado Missiles for Nuclear Power Plants", March 2007.</p> <p>Calculated as 20% of the maximum wind speed (PPE Parameter 1.6.4) (per US NRC RG-1.76 Rev1, page 5, last paragraph).</p>	Yes

Report

OPG Proprietary		
Document Number: N-REP-01200-10000	Usage Classification: N/A	
Sheet Number: N/A	Revision Number: R006	Page: Page 52 of 147

Title: Use of Plant Parameters Envelope to Encompass the Reactor Designs being considered for the Darlington Site

PPE Parameter	Definition	PPE Limiting Value	Limiting Reactor	Darlington Site Characteristic Value	Comments	Bounded by PPE Value?
					Note that the value is assumed to be characteristic of the Darlington site and is conservative because maximum wind speed is taken as the upper limit of an EF-4 category tornado, and that the value is not a measured value for the Darlington site.	
1.6.4	Maximum Wind Speed The design assumption for the sum of maximum rotational and maximum translational wind speed components	368 km/h (230 mph)	EPR	321.8 km/h (200 mph)	<p>The 368 km/h value from the PPE is a conversion from 230 mph using a factor of 1.6 km/mile rather than 1.609 km/h, which would give 370 km/h.</p> <p>Pages 79-85 (Section 3.5.1) of the Evaluation of Meteorological Events report (NK054-REP-0121000013-R001**) describes the assessment performed of the occurrence of tornadoes within an area of 100,000 km² around the Darlington site during the past 50 to 60 years. Two Fujita scale category 4 (F4) tornadoes were observed within 180 km of the site during that time. The predicted probability was approximately 10⁻⁴ per year corresponding to an F-4 category of damage for the Darlington site.</p> <p>The Darlington site was chosen to have a characteristic value of 321.8 km/h (200 mph) for maximum wind speed, corresponding to the upper limit for an Enhanced Fujita scale 4 (EF-4) tornado, which causes the same level of damage as an F-4 tornado. Although the F-Scale is officially used to categorize tornadoes in Canada, updated and more representative values of wind speed are available through the use of the EF-Scale, which was officially adopted in the US in early 2007.</p> <p>Note that the value is assumed to be characteristic of the Darlington site and is conservative because maximum wind speed is taken as the upper limit of an EF-4 category tornado, and the value is not a measured value for the Darlington site.</p> <p>It is noteworthy that in the US NRC, Regulatory Guide 1.76 Revision 1, Region I is proximate to the Darlington site and has a probability of 10⁻⁷ per year of a tornado strike exceeding a speed of 370 km/h (230 mph), which is also within the PPE value.</p>	Yes
1.6.5	Missile Spectra The design assumptions regarding missiles that could be ejected either horizontally or vertically from a tornado. The spectra identify mass, dimensions and velocity of credible missiles	A 4000 lb automobile at 105 mph (46.9 m/s) horizontal and 74 mph (33.1 m/s) vertical, a	AP1000	See Table 3.3	This missile spectrum is extracted from Table 2 of US NRC RG-1.76 Rev1, Region 2 values, which correspond to a maximum wind speed of 200 mph. 200 mph (see Parameter 1.6.4) characterises the Darlington site.	Yes

Report

OPG Proprietary		
Document Number: N-REP-01200-10000	Usage Classification: N/A	
Sheet Number: N/A	Revision Number: R006	Page: Page 53 of 147

Title: Use of Plant Parameters Envelope to Encompass the Reactor Designs being considered for the Darlington Site

PPE Parameter	Definition	PPE Limiting Value	Limiting Reactor	Darlington Site Characteristic Value	Comments	Bounded by PPE Value?	
		275 lb 8 inch shell at 105 mph horizontal and 74 mph vertical, and a 1 inch diameter steel ball at 105 mph horizontal and 105 mph vertical			Note that the mass of the pipe (shell) for the AP1000 missile spectrum is 12 lbs (4%) lower than the mass of the pipe from RG-1.76, but horizontal velocity (VMhmax) and the vertical velocity (0.67*VMhmax) of the AP1000 pipe are 28.9 mph (38%) and 23 mph (31%) higher, respectively. Therefore momentum, (Mass x Velocity) is bounded.		
1.6.6	Radius of Maximum Rotational Speed	46 m	EPR, EC6, AP1000, ACR-1000	45.7 m (150 ft)	This value was based on the US NRC Regulatory Guide 1.76 Rev1 entitled "Design-Basis Tornado and Tornado Missiles for Nuclear Power Plants", March 2007 on page 5, last paragraph. This value is used for all regions in the US, and is therefore assumed for the Darlington site, which is proximate to the US.	Yes	
1.6.7	Rate of Pressure Drop	3.447 kPa/s (0.5 psi/s)	EPR	2.5 kPa/s (0.36 psi/s)	This value was based on the US NRC Regulatory Guide 1.76 Rev1 entitled "Design-Basis Tornado and Tornado Missiles for Nuclear Power Plants", March 2007. The rate of pressure drop is calculated as the maximum pressure drop (Parameter 1.6.1) times the maximum translational speed (Parameter 1.6.3) divided by the radius of maximum rotational speed (Parameter 1.6.6) (per US NRC RG-1.76 Rev1, page 5, last paragraph). Note that the value is assumed to be characteristic of the Darlington site and is conservative because maximum wind speed is taken as the upper limit of an EF-4 category tornado, and the value is not a measured value for the Darlington site.	Yes	
1.7 Wind							
1.7.1	Basic Wind Speed	232 km/h (145 mph)	EPR, AP1000, EC6	154 km/h	The 154 km/h value is for the highest recorded wind gust within 180 km of the site (see Evaluation of Meteorological Events report, NK054-REP-01210-00013-R001** page 85)	Yes	
1.7.2	Importance Factors	Multiplication factors (as defined in ANSI A58 1-1982) applied to basic wind speed to develop the plant design	1.0 Non-Safety Related 1.15 Safety Related	EPR, AP1000, EC6, ACR-1000	1 1.15	Importance factors are not site characteristics, but rather requirements used in the plant design. Importance factors for wind load at the Darlington site shown here are from the National Building Code of Canada (NBCC). For the current version of the NBCC, see 2005, Volume 1, Division B, Part 4, Section 4.1.7 (Wind Load), Table 4.1.7.1 entitled "Importance Factor for Wind Load Iw" on page 4-17.	Yes
2 Normal Plant Heat Sink							

Report

OPG Proprietary		
Document Number: N-REP-01200-10000	Usage Classification: N/A	
Sheet Number: N/A	Revision Number: R006	Page: Page 54 of 147
Title: Use of Plant Parameters Envelope to Encompass the Reactor Designs being considered for the Darlington Site		

PPE Parameter	Definition	PPE Limiting Value	Limiting Reactor	Darlington Site Characteristic Value	Comments	Bounded by PPE Value?	
2.1 Ambient Air Requirements							
2.1.1	Normal Shutdown Max Ambient Temp (1% Exceedance)	Assumption used for the maximum ambient temperature that will be exceeded no more than 1% of the time, to design plant systems capable of effecting normal shutdown under the assumed temperature condition	34.0°C DB	EC6	29.0 °C DB	Based on Toronto Island, Oshawa and Darlington data. The coincident wet bulb temperature is not the limiting wet bulb temperature. The limiting web bulb temperature is listed as Parameter 2.1.2.	Yes
2.1.2	Normal Shutdown Max Wet Bulb Temp (1% Exceedance)	Assumption used for the maximum wet bulb temperature that will be exceeded no more than 1% of the time - used in design of plant systems that must be capable of effecting normal shutdown under the assumed temperature condition	26.5 °C WB (non-coincident)	ACR-1000	23 °C WB	Wet bulb temperature values are not normally collected as part of standard meteorological monitoring at the Darlington station, and thus are not readily available for the NND site. Therefore, it is appropriate to use the National Building Code of Canada as the source of a surrogate value, which specifies 23°C WB for the Bowmanville area. This 23°C WB value is a 2.5% exceedance value based on July data (hottest part of the year and thus conservatively high). For 5%, 1% and 0% WB exceedance values, AECL has confirmed 24°C, 26.5°C and 30.0°C for the ACR-1000. Linear interpolation gives 25.6°C for the 2.5% WB exceedance value, which bounds the 23°C WB value from NBCC. At this revised PPE value, the ACR-1000 is still the limiting reactor for this PPE parameter. Although the provided WB values (design & site) are not directly comparable (because they are at different % exceedances), the NBCC value is appropriate to adopt as the site characteristic value for design purposes.	Yes
2.1.3	Normal Shutdown Min Ambient Temp (1% Exceedance)	Assumption used for the minimum ambient temperature that will be exceeded no more than 1% of the time to design of plant systems that must be capable of effecting normal shutdown under the assumed temperature condition	minus 24°C	EC6	minus 18.0 °C	Based on Toronto Island, Oshawa and Darlington data.	Yes
2.1.4	Rx Thermal Power Max Ambient Temp (0% Exceedance)	Assumption used for the maximum ambient temperature that will never be exceeded - used in design of plant systems that must be capable of supporting full power operation under the assumed temperature condition	39.0°C DB	EC6	37.0 °C DB	The 37.0 °C DB is Based on Toronto Island, Oshawa and Darlington data. The coincident wet bulb temperature is not the limiting wet bulb temperature. The limiting web bulb temperature is listed as Parameter 2.1.5.	Yes
2.1.5	Rx Thermal Power	Assumption used for the maximum wet bulb temperature that will never be exceeded -	27.2°C WB (non-coincident)	EPR, AP1000	23 °C WB	Wet bulb temperature values are not normally collected as part of standard meteorological monitoring at the Darlington station and thus do not exist specifically for the Darlington site.	Yes

Report

OPG Proprietary		
Document Number: N-REP-01200-10000	Usage Classification: N/A	
Sheet Number: N/A	Revision Number: R006	Page: Page 55 of 147

Title: Use of Plant Parameters Envelope to Encompass the Reactor Designs being considered for the Darlington Site

PPE Parameter	Definition	PPE Limiting Value	Limiting Reactor	Darlington Site Characteristic Value	Comments	Bounded by PPE Value?
Max Wet Bulb Temp (0% Exceedance)	used in design of plant systems that must be capable of supporting full power operation under the assumed temperature condition				Therefore, it is appropriate to use the National Building Code of Canada as the source of a surrogate value, which specifies 23°C WB for the Bowmanville area. This 23°C WB is a 2.5% exceedance value based on July data (hottest part of the year and thus conservatively high). The EPR and AP1000 reactors specify a limiting WB temperature of 27.2°C WB and are therefore both limiting technologies. Although the provided WB values (design & site) are not directly comparable (because they are at different % exceedances), the NBCC value is appropriate to adopt as the site characteristic value for design purposes, and the margin for standard designs is 4.2°C.	
2.1.6 Rx Thermal Power Min Ambient Temp (0% Exceedance)	Assumption used for the minimum ambient temperature that will never be exceeded - used in design of plant systems that must be capable of supporting full power operation under the assumed temperature condition	minus 33°C	EC6	minus 30.5 °C	Based on Toronto Island, Oshawa and Darlington data.	Yes
2.3 Condenser						
2.3.1 Max Inlet Temp Condenser/Heat Exchanger	Design assumption for the maximum acceptable circulating water temperature at the inlet to the condenser or cooling water system heat exchangers	25.5 °C	EC6, ACR-1000	24.0 °C	<p>AECL has confirmed a value of 25.5°C for the ACR-1000 and EC6 for this PPE parameter. The values in PPE R2 Table 3 (21 °C, 18.8 °C) for the ACR-1000 correspond to a different interpretation of this parameter, namely the limits on turbine power rating to meet performance warranted. The correct interpretation of this parameter is the condenser design maximum temperature for pressure boundary/registration, which is 25.5 °C for the ACR-1000 and EC6, which bounds the site characteristic value of 24.0 °C (this is the same value as Parameter 3.2.1).</p> <p>The temperature of 24.0 °C is based on measurement from Jan 1993 to Oct 1998, which represents the maximum daily intake temperature for condenser cooling water under operational conditions (page 4-11 and page 4-12, Surface Water Environment - Existing Environmental Conditions TSD, NK054-REP-07730-00002-R000**). A maximum surface water temperature of 22.6 °C for Lake Ontario, for the period of 1971 to 2000, was also reported in the Climate Change Research Information Note published by the Ministry of Natural Resources of Ontario (J. Trumpickas, B.J. Shutter and C.K. Minns, 2008, Potential Changes in Future Water Temperatures in the Ontario Great Lakes as a Result of Climate Change, Climate Change. Research information note ISBN 978-1-42493366-2). The 24.0 °C was chosen as it is the conservative value from the two.</p>	Yes

Report

OPG Proprietary		
Document Number: N-REP-01200-10000	Usage Classification: N/A	
Sheet Number: N/A	Revision Number: R006	Page: Page 56 of 147

Title: Use of Plant Parameters Envelope to Encompass the Reactor Designs being considered for the Darlington Site

PPE Parameter	Definition	PPE Limiting Value	Limiting Reactor	Darlington Site Characteristic Value	Comments	Bounded by PPE Value?	
3 Ultimate Heat Sink							
3.1 Ambient Air Requirements							
3.1.1	Max Ambient Temperature (0% Exceedance)	Assumption used for the maximum ambient temperature in designing the Ultimate Heat Sink (UHS) system to provide heat rejection for 30 days under the assumed temperature condition	39°C DB	EC6	37.0 °C DB	The 37.0 °C DB is Based on Toronto Island, Oshawa and Darlington data. The coincident wet bulb temperature is not the limiting wet bulb temperature. The limiting web bulb temperature is listed as parameter 3.1.2.	Yes
3.1.2	Max Wet Bulb Temperature (0% Exceedance)	Assumption used for the maximum wet bulb temperature in designing the UHS system to provide heat rejection for 30 days under the assumed temperature condition	26.7°C WB (Non-Coincident)	AP1000	23 °C WB	Wet bulb temperature values are not normally collected as part of standard meteorological monitoring at the Darlington station and thus do not exist specifically for the Darlington site. Therefore, it is appropriate to use the National Building Code of Canada as the source of a surrogate value, which specifies 23°C WB for the Bowmanville area. This 23°C WB is a 2.5% exceedance value based on July data (hottest part of the year and thus conservatively high). Although the provided WB values (design & site) are not directly comparable (because they are at different % exceedances), the NBCC value is appropriate to adopt as the site characteristic value for design purposes, and the 26.7°C WB value for the AP1000 is for 30 days, which is an 8.2% exceedance, and thus clearly bounds the site value.	Yes
3.1.3	Min Ambient Temperature (0% Exceedance)	Assumption used for the minimum ambient temperature in designing the UHS system to provide heat rejection for 30 days under the assumed temperature condition	minus 33°C	EC6	minus 30.5 °C	Based on Toronto Island, Oshawa and Darlington data.	Yes
3.2 UHS Heat Exchanger							
3.2.1	Maximum Inlet Temp to UHS Heat Exchanger	The maximum temperature of safety-related service water at the inlet of the UHS component cooling water heat exchanger	25.5 °C	EC6, ACR-1000	24.0 °C	The temperature of 24.0 °C is based on measurement from Jan 1993 to Oct 1998, which represents the maximum daily intake temperature for Condenser Cooling Water under operational conditions (page 4-11 and page 4-12, Surface Water Environment - Existing Environmental Conditions TSD, NK054-REP-07730-00002-R000**). A maximum surface water temperature of 22.6 °C for Lake Ontario, for the period of 1971 to 2000, was also reported in the Climate Change Research Information Note published by the Ministry of Natural Resources of Ontario (J. Trumpickas, B.J. Shutter and C.K. Minns, 2008, Potential Changes in Future Water Temperatures in the Ontario Great Lakes as a Result of Climate Change, Climate Change. Research information note ISBN 978-1-42493366-2). The 24.0 °C was chosen as it is the conservative value from the two.	Yes

Report

OPG Proprietary		
Document Number: N-REP-01200-10000	Usage Classification: N/A	
Sheet Number: N/A	Revision Number: R006	Page: Page 57 of 147

Title: Use of Plant Parameters Envelope to Encompass the Reactor Designs being considered for the Darlington Site

PPE Parameter	Definition	PPE Limiting Value	Limiting Reactor	Darlington Site Characteristic Value	Comments	Bounded by PPE Value?	
4 Containment Heat Removal System (Post Accident)							
4.1 Ambient Air Requirements							
4.1.1	Maximum Ambient Air Temperature (0% Exceedance)	Assumed maximum ambient temperature used in designing the containment heat removal system	43°C DB	EC6, ACR-1000	37.0 °C DB	The 37.0°C DB is based on Toronto Island, Oshawa and Darlington data. The wet bulb temperature is not a limiting temperature.	Yes
4.1.2	Minimum Ambient Temperature (0% Exceedance)	Assumed minimum ambient temperature used in designing the containment heat removal system	minus 33°C	EC6	minus 30.5 °C	Based on Toronto Island, Oshawa and Darlington data.	Yes
14 Heating, Ventilation and Air Conditioning System							
14.1 Ambient Air Requirements							
14.1.1	Non-safety HVAC max ambient temp (1% exceedance)	Assumption used for the maximum ambient temperature that will be exceeded no more than 1% of the time, to design the non-safety HVAC systems	34°C DB	EC6	29.0 °C DB	Based on Toronto Island, Oshawa and Darlington data. The coincident wet bulb temperature is not a limiting temperature.	Yes
14.1.2	Non-safety HVAC min ambient temp (1% exceedance)	Assumption used for the minimum ambient temperature that will be exceeded no more than 1% of the time, to design the non-safety HVAC systems	minus 24°C	EC6	minus 18.0 °C	Based on Toronto Island, Oshawa and Darlington data.	Yes
14.1.3	Safety HVAC max ambient temp (0% Exceedance)	Assumption used for the maximum ambient temperature that will never be exceeded, to design the safety-related HVAC systems	39°C DB	EC6	37.0 °C DB	The 37.0 °C DB is based on Toronto Island, Oshawa and Darlington data. The coincident wet bulb temperature is not a limiting temperature.	Yes
14.1.4	Safety HVAC min ambient temp (0% Exceedance)	Assumption used for the minimum ambient temperature that will never be exceeded, to design the safety-related HVAC systems	minus 33°C	EC6	minus 30.5 °C	Based on Toronto Island, Oshawa and Darlington data.	Yes
14.1.5	Vent System max ambient temp (5% exceedance)	Assumption used for the maximum ambient temperature that will be exceeded no more than 5% of the time to design the non-HVAC ventilation systems	27.3°C DB, 20.1°C WB coincident, 22.3°C WB noncoincident (5% exceedance)	EC6	25.0 °C DB	Based on Toronto Island, Oshawa and Darlington data.	Yes
14.1.6	Vent System min ambient temp (5% exceedance)	Assumption used for the minimum ambient temperature that will be exceeded no more than 5% of the time to design the non-HVAC ventilation systems	minus 12°C	EC6	minus 10.3 °C	Based on Toronto Island, Oshawa and Darlington data.	Yes

Report

OPG Proprietary		
Document Number: N-REP-01200-10000		Usage Classification: N/A
Sheet Number: N/A	Revision Number: R006	Page: Page 58 of 147

Title:
Use of Plant Parameters Envelope to Encompass the Reactor Designs being considered for the Darlington Site

Table 3. 1: UHRS Spectral Acceleration and Frequency

Spectral Frequency (Hz)	Spectral Acceleration (5% damping) Based on Mean Hazard		Spectral Acceleration (5% damping) Based on 84 th Percentile Hazard	
	Horizontal	Vertical	Horizontal	Vertical
100	0.209	0.163	0.276	0.215
62.5	0.286	0.258	0.387	0.348
40	0.385	0.324	0.533	0.448
25	0.446	0.335	0.601	0.451
10	0.375	0.251	0.514	0.345
5	0.259	0.173	0.349	0.234
2.5	0.181	0.121	0.258	0.173
1	0.052	0.035	0.077	0.052
0.5	0.020	0.013	0.033	0.022
0.25	0.005	0.003	0.011	0.007

Table 3. 2: Spectral Accelerations at 100 Hz

Spectral Acceleration (5% damping) Based on Mean Hazard		Spectral Acceleration (5% damping) Based on 84 th Percentile Hazard	
Horizontal	Vertical	Horizontal	Vertical
0.209	0.163	0.276	0.215

Report

OPG Proprietary		
Document Number: N-REP-01200-10000		Usage Classification: N/A
Sheet Number: N/A	Revision Number: R006	Page: Page 59 of 147

Title:
Use of Plant Parameters Envelope to Encompass the Reactor Designs being considered for the Darlington Site

Table 3. 3: Tornado Missile Spectrum and Maximum Horizontal Speeds

Missile Type	Dimensions	Mass	Horizontal Velocity (V_{Mh}^{max})	Vertical Velocity ($0.67 * V_{Mh}^{max}$)
Schedule 40 Pipe	0.168 m dia x 4.58 m long (6.625 in dia x 15 ft long)	130 kg (287 lb)	34 m/s (76.1 mph)	22.8 m/s (51.0 mph)
Automobile	5 m x 2 m x 1.3 m (16.4 ft x 6.6 ft x 4.3 ft)	1810 kg (4000 lb)	34 m/s (76.1 mph)	22.8 m/s (51.0 mph)
Solid Steel Sphere	2.54 cm dia (1 in dia)	0.0669 kg (0.147 lb)	7 m/s (15.7 mph)	4.7 m/s (10.5 mph)

B.1.4 Table 4: Consolidated PPE Parameters, Values, Where Used and How Used

Table 4: Consolidated PPE Parameters, Values, Where Used and How Used

(see Following pages)

:

Report

OPG Proprietary		
Document Number: N-REP-01200-10000	Usage Classification: N/A	
Sheet Number: N/A	Revision Number: R006	Page: Page 60 of 147
Title: Use of Plant Parameters Envelope to Encompass the Reactor Designs being considered for the Darlington Site		

PPE Parameter			Prorated	PPE Single Unit Value PPE Pro-rated Value*	Limiting Reactor	Where Used	How Used
ID No.	Name	Definition					
0.1	Electric Output	The electrical output of the plant	Y	1708 MWe (gross) 5124 MWe (gross)	EPR EPR	Scope of Project TSD: Section 2.1 ACR - Section 4.1 EPR – Section 4.2 AP1000 - Section 4.3 Communication and Consultation TSD: Q&A 58, Q&A 109	Provided as project description In response to questions related to electric output.
0.2	Megawatts Thermal	The thermal output of the plant, including electrical output and rejected heat load	Y	4,590 MWth 13,770 MWth	EPR EPR	Not used in Environmental Impact Statement or Site Evaluation Studies	N/A
0.3	Station Capacity Factor	The percentage of time the plant is expected to deliver its stated electrical output over the lifetime of the plant, considering all expected outages	N	94%	EPR	Not used in Environmental Impact Statement or Site Evaluation Studies	N/A
0.4	Plant Design Life	The designed lifetime of the plant, including planned midlife refurbishments	N	60 y	EPR, AP1000, EC6, ACR-1000	Scope of Project TSD: Section 1.1.1 Given in Section 1.1.1 of other TSDs Nuclear Waste Management TSD: Section 3.2 Terrestrial Environmental Assessment of Environmental Effects TSD: Section 3.5	Provided as project description. Basis for assessment of the expected waste arising over a 60 year reactor operating life. Basis for predicting the temperature in southern Ontario over the next 50-60 years.
						Site Evaluation Report – Evaluation of Geotechnical Aspects: Pg 55 (Table 5.1-2), Pg 60-62 (Section 5.3), Pg 86-88 (Section 8.2), Pg 88-91 (Section 8.3), Pg 91-93 (Section 8.4), Pg 93 (Section 8.5) This value was not shown in the Site Evaluation Report – Dispersion of Radioactive Materials in Air and Water but was used to estimate dose to the public.	Considered for the foundation design and stability of slopes. Used as an input parameter in the model to estimate doses to the public during normal operations.
1.1 Building Characteristics							

* - For 3 units for EPR, or 4 units for BWRX-300, AP1000, ACR-1000, or EC6

Report

OPG Proprietary		
Document Number: N-REP-01200-10000	Usage Classification: N/A	
Sheet Number: N/A	Revision Number: R006	Page: Page 61 of 147

Title: Use of Plant Parameters Envelope to Encompass the Reactor Designs being considered for the Darlington Site

PPE Parameter			Prorated	PPE Single Unit Value PPE Pro-rated Value*	Limiting Reactor	Where Used	How Used
ID No.	Name	Definition					
1.1.1	Height	The height from finished grade to the top of the tallest power block structure, excluding cooling towers	N	71.3 m	AP1000	Scope of Project TSD: Section 4.4 Atmospheric Environment Assessment of Effects TSD, Appendix C Site Evaluation Report – Dispersion of Radioactive Materials in Air and Water: Page 52 (Table 3.1-2) Site Evaluation Report – Evaluation of Geotechnical Aspects: Pg 55 (Table 5.1-2), Pg 60-61 (Section 5.3), Pg 61-62 (Section 5.4), Pg 62-64 (Section 5.5) Site Evaluation Report – Nuclear Safety Considerations, Page 66 (Section 5.2.1)	Input to atmospheric dispersion modelling Input to atmospheric dispersion modelling. Considered for the evaluation of the foundation and the bearing capacity. To calculate doses during normal operations.
1.1.2	Foundation Embedment	The depth from finished grade to the bottom of the basemat for the most deeply embedded power block structure	N	38 m	BWRX-300	Evaluated in [R-13]. Originally used in: Site Evaluation Report – Evaluation of Geotechnical Aspects: Pg 55 (Table 5.1-2), Pg 60 (Section 5.3.1), Pg 62 (Section 5.4.1), Pg 63 (Section 5.5.3), Pg 64 (Section 5.6)	Considered for the evaluation of the foundation and the bearing capacity.
1.2 Precipitation (for Roof Design)							
1.2.1	Maximum Rainfall Rate	The Probable Maximum Precipitation (PMP) value that can be accommodated by a plant design. Expressed as maximum precipitation for 1 hour in 1 square km and as maximum precipitation for 5 minutes in 1 square km	N	400 mm/day; 100 mm/hour; 30 mm/15 min	EC6, ACR-1000	Site Evaluation Report – Nuclear Safety Considerations Page 51 (Section 3.11) See attached table of Darlington Site Characteristic Values	The Nuclear Safety Considerations report demonstrates that the highest rainfall level expected can be accommodated by all three technologies. Comparison to Darlington Site Characteristic Values.
1.2.2	Snow & Ice Load	The maximum load on structure roofs due to the accumulation of snow and ice that can be accommodated by a plant design	N	3.0 kPa	EC6	See attached table of Darlington Site Characteristic Values	Comparison to Darlington Site Characteristic Values.
1.3 Design Basis Earthquake							
1.3.1	Design Response Spectra	The assumed design response spectra used to establish a plant's seismic design	N	Canadian Regulatory Approach to site design basis earthquake	EPR, AP1000, EC6,	Site Evaluation Report – Evaluation of Geotechnical Aspects: Pg 54 (Table 5.1-1), Pg 84 (Section 7.3.2), Pg 178 (Appendix C)	Considered for the ground response analysis (i.e. liquefaction analysis) of the site.

* - For 3 units for EPR, or 4 units for BWRX-300, AP1000, ACR-1000, or EC6

Report

OPG Proprietary		
Document Number: N-REP-01200-10000	Usage Classification: N/A	
Sheet Number: N/A	Revision Number: R006	Page: Page 62 of 147

Title: Use of Plant Parameters Envelope to Encompass the Reactor Designs being considered for the Darlington Site

PPE Parameter			Prorated	PPE Single Unit Value PPE Pro-rated Value*	Limiting Reactor	Where Used	How Used
ID No.	Name	Definition					
					ACR-1000	See attached table of Darlington Site Characteristic Values	Comparison to Darlington Site Characteristic Values.
1.3.2	Design Peak Ground Acceleration	The maximum earthquake ground acceleration for which a plant is designed, this is defined as the acceleration which corresponds to the zero period in the response spectra taken in the free field at plant grade elevation	N	0.3 g	EPR, AP1000, EC6, ACR-1000	Site Evaluation Report – Evaluation of Geotechnical Aspects: Pg 54 (Table 5.1-1), Pg 83 (Section 7.3.1), Pg 86 (Section 8.2.2), Pg 88 (Section 8.3.2), Pg 91 (Section 8.4.2) Site Evaluation Report – Nuclear Safety Considerations - Pg 46 (Section 3.6.5), Pg 51 (Section 3.11), Pg 75 (Section 6.0) Pg 47 (Figure 3-2) & Site Evaluation Report – Part 3: Summary of Seismic Hazard Evaluations - Pg 17 (Section 2.8) Pg 21 (Section 4.2), Pg 37 (Figure 9) & Site Evaluation Report – Probabilistic Seismic Hazard Assessment Pg 174 (Section 5.3.6), Pg 209 (Figure 5-28) Pg 213 (Section 7.0), Pg 215 (Figure 7-1)	To calculate the stability of slopes under earthquake loading. Consistent with the value of this PPE parameter, 0.3g spectra were used in the seismic design response of the available vendor designs under consideration for Ontario.
						See attached table of Darlington Site Characteristic Values	Comparison to Darlington Site Characteristic Values.
1.3.3	Time History	The plot of earthquake ground motion as a function of time used to establish a plant's seismic design	N	Canadian Regulatory Approach to site design basis earthquake	EPR, EC6, AP1000, ACR-1000	See attached table of Darlington Site Characteristic Values	Comparison to Darlington Site Characteristic Values.
1.3.4	Capable Tectonic Structures or Sources	The assumption made in a plant design about the presence of capable faults or earthquake sources in the vicinity of the plant site (e.g., No fault displacement potential within the investigative area)	N	No fault displacement within the site area	EPR, AP1000, EC6, ACR-1000	Site Evaluation Report – Evaluation of Geotechnical Aspects: Page 54 (Table 5.1-1)	Based on information provided relevant to this PPE parameter, no geological fault is considered for foundation and slope stability analysis.
						See attached table of Darlington Site Characteristic Values	Comparison to Darlington Site Characteristic Values.
1.4 Site Water Level (Allowable)							
1.4.1	Maximum Flood (or Tsunami)	Design assumption regarding the difference in elevation	N	0.341 m (1 ft) below grade	EPR	Site Evaluation Report – Evaluation of Geotechnical Aspects: Pg 54 (Table 5.1-1), Pg 84 (Section 7.5)	For the evaluation and design of the foundation with respect to buoyancy.

* - For 3 units for EPR, or 4 units for BWRX-300, AP1000, ACR-1000, or EC6

Report

OPG Proprietary		
Document Number: N-REP-01200-10000	Usage Classification: N/A	
Sheet Number: N/A	Revision Number: R006	Page: Page 63 of 147
Title: Use of Plant Parameters Envelope to Encompass the Reactor Designs being considered for the Darlington Site		

PPE Parameter			Prorated	PPE Single Unit Value PPE Pro-rated Value*	Limiting Reactor	Where Used	How Used
ID No.	Name	Definition					
		between finished plant grade and the water level due to the probable maximum flood (or Tsunami)				See attached table of Darlington Site Characteristic Values	Comparison to Darlington Site Characteristic Values.
1.4.2	Maximum Ground Water	Design assumption regarding the difference in elevation between finished plant grade and the maximum site ground water level used in the plant design	N	-1 m (-3.3 ft) from plant grade	EPR, EC6	Site Evaluation Report – Evaluation of Geotechnical Aspects: Page 54 (Table 5.1-1), Page 84 (Section 7.5) Page 87 (Section 8.2.3), Page 90 (Section 8.3.3), Page 92 & 93 (Section 8.4.3)	For the evaluation and design of the foundation with respect to buoyancy and calculation of stability of slopes.
						See attached table of Darlington Site Characteristic Values	Comparison to Darlington Site Characteristic Values.
1.5 Soil Properties Design Bases							
1.5.1	Liquefaction	Design assumption regarding the presence of potentially liquefying soils at a site	N	No liquefaction is permitted at the site	EPR, AP1000, EC6, ACR-1000	Site Evaluation Report – Evaluation of Geotechnical Aspects: Pg 54 (Table 5.1-1), Pg 178 (Appendix C)	For the liquefaction assessment of the site (Appendix C).
						See attached table of Darlington Site Characteristic Values	Comparison to Darlington Site Characteristic Values.
1.5.2	Minimum Required Bearing Capacity (Static)	Design assumption regarding the capacity of the competent load-bearing layer required to support the loads exerted by plant structures used in the plant design	N	718 kPa	EPR, EC6	Site Evaluation Report – Evaluation of Geotechnical Aspects: Pg 54 (Table 5.1-1), Pg 63 (Section 5.5.1)	To assess the bearing capacity of soil/rock.
						See attached table of Darlington Site Characteristic Values	Comparison to Darlington Site Characteristic Values.
1.5.3	Minimum Shear Wave Velocity	The assumed limiting propagation velocity of shear waves through the foundation materials used in the plant design	N	304.8 m/s	AP1000, EC6	Site Evaluation Report – Evaluation of Geotechnical Aspects: Pg 54 (Table 5.1-1), Pg 178 (Appendix C)	For the liquefaction assessments of the site (Appendix C).
						See attached table of Darlington Site Characteristic Values	Comparison to Darlington Site Characteristic Values.
1.6 Design Basis Tornado							
1.6.1	Maximum Pressure Drop	The design assumption for the decrease in ambient pressure from normal atmospheric pressure due to the passage of the tornado	N	8.274 kPa	EPR	See attached table of Darlington Site Characteristic Values	Comparison to Darlington Site Characteristic Values.

* - For 3 units for EPR, or 4 units for BWRX-300, AP1000, ACR-1000, or EC6

Report

OPG Proprietary		
Document Number: N-REP-01200-10000	Usage Classification: N/A	
Sheet Number: N/A	Revision Number: R006	Page: Page 64 of 147
Title: Use of Plant Parameters Envelope to Encompass the Reactor Designs being considered for the Darlington Site		

PPE Parameter			Prorated	PPE Single Unit Value PPE Pro-rated Value*	Limiting Reactor	Where Used	How Used
ID No.	Name	Definition					
1.6.2	Maximum Rotational Speed	The design assumption for the component of tornado wind speed due to the rotation within the tornado	N	296 km/h	EPR	See attached table of Darlington Site Characteristic Values	Comparison to Darlington Site Characteristic Values.
1.6.3	Maximum Translational Speed	The design assumption for the component of tornado wind speed due to the movement of the tornado over the ground	N	74 km/h	EPR	See attached table of Darlington Site Characteristic Values	Comparison to Darlington Site Characteristic Values.
1.6.4	Maximum Wind Speed	The design assumption for the sum of maximum rotational and maximum translational wind speed components	N	368 km/h	EPR	Site Evaluation Report – Nuclear Safety Considerations Page 51 (Section 3.11)	The Nuclear Safety Considerations report demonstrates that the highest wind speed expected can be accommodated by all three technologies.
						See attached table of Darlington Site Characteristic Values	Comparison to Darlington Site Characteristic Values.
1.6.5	Missile Spectra	The design assumptions regarding missiles that could be ejected either horizontally or vertically from a tornado. The spectra identify mass, dimensions and velocity of credible missiles	N	A 4000 pound automobile at 105 mph (46.9 m/s) horizontal and 74 mph (33.1 m/s) vertical, a 275 pound 8 inch shell at 105 mph horizontal and 74 mph vertical, and a 1 inch diameter steel ball at 105 mph horizontal and 105 mph vertical	AP1000	See attached table of Darlington Site Characteristic Values	Comparison to Darlington Site Characteristic Values.
1.6.6	Radius of Maximum Rotational Speed	The design assumption for distance from the center of the tornado at which the maximum rotational wind speed occurs	N	46 m	EPR, EC6 AP1000, ACR-1000	See attached table of Darlington Site Characteristic Values	Comparison to Darlington Site Characteristic Values.
1.6.7	Rate of Pressure Drop	The assumed design rate at which the pressure drops due to the passage of the tornado	N	3.447 kPa/s	EPR	See attached table of Darlington Site Characteristic Values	Comparison to Darlington Site Characteristic Values.
1.7 Wind							

* - For 3 units for EPR, or 4 units for BWRX-300, AP1000, ACR-1000, or EC6

Report

OPG Proprietary		
Document Number: N-REP-01200-10000	Usage Classification: N/A	
Sheet Number: N/A	Revision Number: R006	Page: Page 65 of 147
Title: Use of Plant Parameters Envelope to Encompass the Reactor Designs being considered for the Darlington Site		

PPE Parameter			Prorated	PPE Single Unit Value PPE Pro-rated Value*	Limiting Reactor	Where Used	How Used
ID No.	Name	Definition					
1.7.1	Basic Wind Speed	The design wind for which the facility is designed	N	232 kmh / 145 mph	EPR, AP1000, EC6	Site Evaluation Report – Nuclear Safety Considerations Page 51 (Section 3.11)	The Nuclear Safety Considerations report demonstrates that the highest wind speed expected can be accommodated by all three technologies.
						See attached table of Darlington Site Characteristic Values	Comparison to Darlington Site Characteristic Values.
1.7.2	Importance Factors	Multiplication factors (as defined in ANSI A58 1-1982) applied to basic wind speed to develop the plant design	N	1.0 non safety; 1.15 safety related	EPR, EC6, AP1000, ACR-1000	See attached table of Darlington Site Characteristic Values	Comparison to Darlington Site Characteristic Values.
2 Normal Plant Heat Sink							
2.1 Ambient Air Requirements							
2.1.1	Normal Shutdown Max Ambient Temp (1% Exceedance)	Assumption used for the maximum ambient temperature that will be exceeded no more than 1% of the time, to design plant systems capable of effecting normal shutdown under the assumed temperature condition	N	34.0°C DB	EC6	See attached table of Darlington Site Characteristic Values	Comparison to Darlington Site Characteristic Values.
2.1.2	Normal Shutdown Max Wet Bulb Temp (1% Exceedance)	Assumption used for the maximum wet bulb temperature that will be exceeded no more than 1% of the time - used in design of plant systems that must be capable of effecting normal shutdown under the assumed temperature condition	N	26.5°C WB (non-coincident)	ACR-1000	See attached table of Darlington Site Characteristic Values	Comparison to Darlington Site Characteristic Values.
2.1.3	Normal Shutdown Min Ambient Temp (1% Exceedance)	Assumption used for the minimum ambient temperature that will be exceeded no more than 1% of the time to design of plant systems that must be	N	minus 24°C	EC6	See attached table of Darlington Site Characteristic Values	Comparison to Darlington Site Characteristic Values.

* - For 3 units for EPR, or 4 units for BWRX-300, AP1000, ACR-1000, or EC6

Report

OPG Proprietary		
Document Number: N-REP-01200-10000	Usage Classification: N/A	
Sheet Number: N/A	Revision Number: R006	Page: Page 66 of 147

Title: Use of Plant Parameters Envelope to Encompass the Reactor Designs being considered for the Darlington Site

PPE Parameter			Prorated	PPE Single Unit Value PPE Pro-rated Value*	Limiting Reactor	Where Used	How Used
ID No.	Name	Definition					
		capable of effecting normal shutdown under the assumed temperature condition					
2.1.4	Rx Thermal Power Max Ambient Temp (0% Exceedance)	Assumption used for the maximum ambient temperature that will never be exceeded - used in design of plant systems that must be capable of supporting full power operation under the assumed temperature condition	N	39°C DB	EC6	See attached table of Darlington Site Characteristic Values	Comparison to Darlington Site Characteristic Values.
2.1.5	Rx Thermal Power Max Wet Bulb Temp (0% Exceedance)	Assumption used for the maximum wet bulb temperature that will never be exceeded - used in design of plant systems that must be capable of supporting full power operation under the assumed temperature condition	N	27.2°C WB (non-coincident)	EPR, AP1000	See attached table of Darlington Site Characteristic Values	Comparison to Darlington Site Characteristic Values.
2.1.6	Rx Thermal Power Min Ambient Temp (0% Exceedance)	Assumption used for the minimum ambient temperature that will never be exceeded - used in design of plant systems that must be capable of supporting full power operation under the assumed temperature condition	N	minus 33°C	EC6	See attached table of Darlington Site Characteristic Values	Comparison to Darlington Site Characteristic Values.
2.2 Blowdown Pond Acreage (24 h blowdown)							
2.2	Blowdown Pond Acreage (24 h)	The land usage required to provide a pond with a capacity to provide holdup for 24 hours of blowdown water from the plant.	Y	14165 m2 56660 m2	ACR-1000 ACR-1000	Not used in Environmental Impact Statement or Site Evaluation Studies	N/A

* - For 3 units for EPR, or 4 units for BWRX-300, AP1000, ACR-1000, or EC6

Report

OPG Proprietary		
Document Number: N-REP-01200-10000	Usage Classification: N/A	
Sheet Number: N/A	Revision Number: R006	Page: Page 67 of 147
Title: Use of Plant Parameters Envelope to Encompass the Reactor Designs being considered for the Darlington Site		

PPE Parameter			Prorated	PPE Single Unit Value PPE Pro-rated Value*	Limiting Reactor	Where Used	How Used
ID No.	Name	Definition					
2.3 Condenser							
2.3.1	Max Inlet Temp Condenser/Heat Exchanger	Design assumption for the maximum acceptable circulating water temperature at the inlet to the condenser or cooling water system heat exchangers	N	25.5°C	EC6, ACR-1000	See attached table of Darlington Site Characteristic Values	Comparison to Darlington Site Characteristic Values.
2.3.2	Condenser/Heat Exchanger Duty	Design value for the waste heat rejected to the circulating water system across the condensers	Y	3,400 MW 10,200 MW	EPR EPR	Not used in Environmental Impact Statement or Site Evaluation Studies	N/A
2.4 Mechanical Draft Cooling Towers							
2.4.1	Acreage	The land required for cooling towers or ponds, including support facilities such as equipment sheds, basins, canals, or shoreline buffer areas	Y	10 ha	AP1000, ACR-1000	Site Evaluation Report – Evaluation of Geotechnical Aspects: Pg 55 (Table 5.1-2), Pg 60-61 (Section 5.3) Pg 61-62 (Section 5.4), Pg 62-64 (Section 5.5)	Considered for the evaluation of the foundation and the bearing capacity.
				40 ha	AP1000, ACR-1000		
2.4.2	Approach Temperature	The difference between the cold water temperature and the ambient wet bulb temperature	N	5.6°C	EPR, AP1000	Scope of Project TSD: Table 4.5-1 Surface Water Environment Assessment of Effects TSD: Section 4.2.4	Used to assess effects of discharge water from cooling towers
						Site Evaluation Report – Evaluation of Geotechnical Aspects: Page 55 (Table 5.1-2)	This PPE parameter related to keeping the foundation frost-free during the winter, but was not used. Instead, the foundation would be built deeper than the frost line of 1.2 m, which is a conservative approach (see section 5.4.2).
2.4.3	Blowdown Constituents and Concentrations	The maximum expected concentrations for anticipated constituents in the cooling water systems blowdown to the receiving water body	N	Refer to Table 4.7	EPR, AP1000, EC6, ACR-1000	Scope of Project TSD: Table 4.5-4 (some of the values are slightly different from the PPE document due to rounding)	Data provided for information purposes.
2.4.4	Blowdown Flow Rate	The normal (and maximum) flow rate of the blowdown stream from the cooling water systems to the receiving water body for closed system designs	Y Y	379 L/s expected 1,546 L/s max 1,514 L/s expected 6,183 L/s max	EPR AP1000 AP1000 AP1000	Not used in Environmental Impact Statement or Site Evaluation Studies	N/A

* - For 3 units for EPR, or 4 units for BWRX-300, AP1000, ACR-1000, or EC6

Report

OPG Proprietary		
Document Number: N-REP-01200-10000	Usage Classification: N/A	
Sheet Number: N/A	Revision Number: R006	Page: Page 68 of 147

Title:
Use of Plant Parameters Envelope to Encompass the Reactor Designs being considered for the Darlington Site

PPE Parameter			Prorated	PPE Single Unit Value PPE Pro-rated Value*	Limiting Reactor	Where Used	How Used
ID No.	Name	Definition					
2.4.5	Blowdown Temperature	The maximum expected blowdown temperature at the point of discharge to the receiving water body	N	37.8°C	AP1000	Scope of Project TSD: section 4.5.2.1, table 4.5-1, page 4-37 includes Blowdown Flow Rate (L/s@°C) – temperature specified for normal plant heat sink for mechanical draft cooling: for PWR limiting value, and for the ACR 1000, 4 units PHR limiting value.	Data provided for information purposes.
						Site Evaluation Report – Evaluation of Geotechnical Aspects: Page 55 (Table 5.1-2)	This PPE parameter related to keeping the foundation frost-free during the winter, but was not used. Instead, the foundation would be built deeper than the frost line of 1.2 m, which is a conservative approach (see section 5.4.2).
2.4.6	Cycles of Concentration	The ratio of total dissolved solids in the cooling water blowdown streams to the total dissolved solids in the makeup water streams	N	4	EPR, EC6 AP1000, ACR-1000	Surface Water Environment Assessment of Effects TSD: Section 4.2.1	Used to calculate releases from cooling towers
2.4.7	Evaporation Rate	The expected (and maximum) rate at which water is lost by evaporation from the cooling water systems	Y	1,137 L/s 3,786 L/s	EPR AP1000	Not used in Environmental Impact Statement or Site Evaluation Studies	N/A
2.4.8	Height	The vertical height above finished grade of either natural draft or mechanical draft cooling towers associated with the cooling water systems	N	19.8 m	EPR	Scope of Project TSD: Sections 2.3.2, 2.4.1.2, 3.2.3.2, 4.5.2.2 Communication and consultation TSD: Question 67 Land Use Assessment of Effects TSD: Table 3.2-1 Atmospheric Environment Assessment of Effects TSD, Appendix E	To define the input parameters for the EA assessment Response to Frequently Asked Questions Input to cooling tower modelling
						Site Evaluation Report – Evaluation of Geotechnical Aspects: Pg 55 (Table 5.1-2), Pg 60-61 (Section 5.3) Pg 61-62 (Section 5.4), Pg 62-64 (Section 5.5)	Considered for the evaluation of the foundation and the bearing capacity.
2.4.9	Makeup Flow Rate	The expected (and maximum) rate of removal of water from a natural source to replace water	Y	1,804 L/s 5,412 L/s	EPR EPR	Not used in Environmental Impact Statement or Site Evaluation Studies	N/A

* - For 3 units for EPR, or 4 units for BWRX-300, AP1000, ACR-1000, or EC6

Report

OPG Proprietary		
Document Number: N-REP-01200-10000	Usage Classification: N/A	
Sheet Number: N/A	Revision Number: R006	Page: Page 69 of 147
Title: Use of Plant Parameters Envelope to Encompass the Reactor Designs being considered for the Darlington Site		

PPE Parameter			Prorated	PPE Single Unit Value PPE Pro-rated Value*	Limiting Reactor	Where Used	How Used
ID No.	Name	Definition					
		losses from closed cooling water systems					
2.4.10	Noise	The maximum expected sound level produced by operation of cooling towers, measured at 1000 feet from the noise source	N	55 dBa at 305 m	AP1000, EC6, ACR-1000	Atmospheric Environment Assessment of Effects TSD: Appendix F, section F.2.3.2, page F.2-6	Used the PPE for the mechanical draft cooling towers noise level as a correction for source power estimates from another reference - to establish noise emissions level from this source.
2.4.11	Cooling Tower Temperature Range	The temperature difference between the cooling water entering and leaving the towers	N	9°C	EC6, ACR-1000	Site Evaluation Report – Evaluation of Geotechnical Aspects: Page 55 (Table 5.1-2)	This PPE parameter related to keeping the foundation frost-free during the winter, but was not used. Instead, the foundation would be built deeper than the frost line of 1.2 m, which is a conservative approach (see section 5.4.2).
2.4.12	Cooling Water Flow Rate	The total cooling water flow rate through the condenser / heat exchangers	Y	57,100 L/s 228,400 L/s	ACR-1000 ACR-1000	Not used in Environmental Impact Statement or Site Evaluation Studies	N/A
2.4.13	Heat Rejection Rate (blowdown)	The expected heat rejection rate to a receiving water body, expressed as flow rate in litres per second at a temperature in degrees Celsius	Y	429 L/s@37.7°C expected 2,020 L/s@37.7°C maximum	EPR EPR	Scope of Project TSD: Table 4.5-1	Data provided for information purposes.
			Y	1,287 L/s@37.7°C expected 6,060 L/s@37.7°C maximum	EPR EPR	These values were not explicitly presented in the Site Evaluation Reports but were used to calculate the discharge rate (mechanical draft cooling).	Used to calculate the discharge rate given in Site Evaluation Report – Dispersion of Radioactive Materials in Air and Water (Table 3.2-2 and Table 3.3.3-1), as part of normal operating dose calculation.
2.4.14	Maximum Consumption of Raw Water	The expected maximum short-term consumptive use of water by the cooling water systems (evaporation and drift losses)	Y	1,893L/s	AP1000	Scope of Project TSD: Table 4.5.1	Data provided for information purposes.
			Y	7,572L/s	AP1000		
2.4.15	Monthly Average Consumption of Raw Water	The expected normal operating consumption of water by the cooling water systems (evaporation and drift losses)	Y	1,325L/s	AP1000	Scope of Project TSD: Table 4.5.1 Surface Water Environment Assessment of Effects TSD: Section 4.2.1	Used for the development of input parameters for surface water modelling.
			Y	5,300L/s	AP1000		

* - For 3 units for EPR, or 4 units for BWRX-300, AP1000, ACR-1000, or EC6

Report

OPG Proprietary		
Document Number: N-REP-01200-10000	Usage Classification: N/A	
Sheet Number: N/A	Revision Number: R006	Page: Page 70 of 147
Title: Use of Plant Parameters Envelope to Encompass the Reactor Designs being considered for the Darlington Site		

PPE Parameter			Prorated	PPE Single Unit Value PPE Pro-rated Value*	Limiting Reactor	Where Used	How Used
ID No.	Name	Definition					
2.4.16	Stored Water Volume	The quantity of water stored in cooling water system impoundments, basins, tanks and/or ponds	Y	8.71E+07 L 2.61E+08 L	EPR EPR	Not used in Environmental Impact Statement or Site Evaluation Studies	N/A
2.5 Natural Draft Cooling Towers							
2.5.1	Acreage	The land required for cooling towers or ponds, including support facilities such as equipment sheds, basins, canals, or shoreline buffer areas	Y	40,470 m2 (10 acres) 121,410 m2 (30 acres)	EPR EPR	Not used in Environmental Impact Statement or Site Evaluation Studies	N/A
2.5.2	Approach Temperature	The difference between the cold water temperature and the ambient wet bulb temperature	N	5.6°C	AP1000	Scope of Project TSD: Table 4.5-1 Surface Water Environment Assessment of Effects TSD: Section 4.2.4 Site Evaluation Report – Evaluation of Geotechnical Aspects: Page 55 (Table 5.1-2)	Used to assess effects of discharge water from cooling towers This PPE parameter related to keeping the foundation frost-free during the winter, but was not used. Instead, the foundation would be built deeper than the frost line of 1.2 m, which is a conservative approach (see section 5.4.2).
2.5.3	Blowdown Constituents and Concentrations	The maximum expected concentrations for anticipated constituents in the cooling water systems blowdown to the receiving water body	N	Refer to Table 4.7	EPR, AP1000, EC6, ACR-1000	Scope of Project TSD: Table 4.5-4 (some of the values are slightly different from the PPE document due to rounding)	Data provided for information purposes.
2.5.4	Blowdown Flow Rate	The normal (and maximum) flow rate of the blowdown stream from the cooling water systems to the receiving water body for closed system designs	Y Y	L/s expected 379 L/s max 1,546 L/s expected 1,514 L/s max 6,183	EPR AP1000 AP1000 AP1000	Scope of Project TSD: Table 4.5-1.	Data provided for information purposes.
2.5.5	Blowdown Temperature	The maximum expected blowdown temperature at the point of discharge to the receiving water body	N	3 °.8°C	EPR, AP1000	Scope of Project TSD: section 4.5.2.1, table 4.5-1, page 4-37 includes Blowdown Flow Rate (L/s@°C) – temperature specified for normal plant heat sink for mechanical draft cooling: for PWR limiting value, and for the ACR 1000, 4 units PHR limiting value.	Data provided for information purposes.

* - For 3 units for EPR, or 4 units for BWRX-300, AP1000, ACR-1000, or EC6

Report

OPG Proprietary		
Document Number: N-REP-01200-10000	Usage Classification: N/A	
Sheet Number: N/A	Revision Number: R006	Page: Page 71 of 147

Title: Use of Plant Parameters Envelope to Encompass the Reactor Designs being considered for the Darlington Site

PPE Parameter			Prorated	PPE Single Unit Value PPE Pro-rated Value*	Limiting Reactor	Where Used	How Used
ID No.	Name	Definition					
						Site Evaluation Report – Evaluation of Geotechnical Aspects: Page 55 (Table 5.1-2)	This PPE parameter related to keeping the foundation frost-free during the winter, but was not used. Instead, the foundation would be built deeper than the frost line of 1.2 m, which is a conservative approach (see section 5.4.2 of Geotechnical Aspects).
2.5.6	Cycles of Concentration	The ratio of total dissolved solids in the cooling water blowdown streams to the total dissolved solids in the makeup water streams	N	4	EPR, AP1000, EC6, ACR-1000	Surface Water Environment Assessment of Effects TSD: Section 4.2.1	Used to calculate releases from cooling towers
2.5.7	Evaporation Rate	The expected (and maximum) rate at which water is lost by evaporation from the cooling water systems	Y	1,137 L/s 3,786 L/s	EPR AP1000	Not used in Environmental Impact Statement or Site Evaluation Studies	N/A
2.5.8	Height	The vertical height above finished grade of either natural draft, mechanical draft or hybrid cooling towers associated with the cooling water systems	N	152.4 m	AP1000	Scope of Project TSD: Sections 2.3.2, 3.2.3.3, 4.5.2.2, 4.5.10 Communication and consultation TSD: Frequently Asked Questions Land Use TSD: Table 3.2-1 Atmospheric Environment Assessment of Effects TSD: Appendix E	To define the input parameters for the EA assessment Response to Frequently Asked Questions Input to cooling tower modelling
2.5.9	Makeup Flow Rate	The expected (and maximum) rate of removal of water from a natural source to replace water losses from closed cooling water systems	Y	1,804 L/s 5,412 L/s	EPR EPR	Not used in Environmental Impact Statement or Site Evaluation Studies	N/A
2.5.10	Noise	The maximum expected sound level produced by operation of cooling towers, measured at 1000 feet from the noise source	N	55 dBa at 305 m	AP1000, EC6, ACR-1000	Atmospheric Environment Assessment of Effects TSD: Appendix F, section F.2.3.2, page F.2-6,	Used the PPE for the mechanical draft cooling towers noise level as a correction for source power estimates from another reference - to establish noise emissions level from this source.

* - For 3 units for EPR, or 4 units for BWRX-300, AP1000, ACR-1000, or EC6

Report

OPG Proprietary		
Document Number: N-REP-01200-10000	Usage Classification: N/A	
Sheet Number: N/A	Revision Number: R006	Page: Page 72 of 147

Title: Use of Plant Parameters Envelope to Encompass the Reactor Designs being considered for the Darlington Site

PPE Parameter			Prorated	PPE Single Unit Value PPE Pro-rated Value*	Limiting Reactor	Where Used	How Used
ID No.	Name	Definition					
2.5.11	Cooling Tower Temperature Range	The temperature difference between the cooling water entering and leaving the towers	N	9 °C	EC6, ACR-1000	Site Evaluation Report – Evaluation of Geotechnical Aspects: Page 55 (Table 5.1-2)	This PPE parameter related to keeping the foundation frost-free during the winter, but was not used. Instead, the foundation would be built deeper than the frost line of 1.2 m, which is a conservative approach (see section 5.4.2).
2.5.12	Cooling Water Flow Rate	The total cooling water flow rate through the condenser / heat exchangers	Y	57,100 L/s 228,400 L/s	ACR-1000 ACR-1000	Not used in Environmental Impact Statement or Site Evaluation Studies	N/A
2.5.13	Heat Rejection Rate (blowdown)	The expected heat rejection rate to a receiving water body, expressed as flow rate in litres per second at a temperature in degrees Celsius	Y	270 L/s@30.3°C 379 L/s@24.4°C	ACR-1000 EPR	Scope of Project TSD: Table 4.5-1	Data provided for information purposes.
				1,080 L/s@30.3°C	ACR-1000	These values were not explicitly presented in the Site Evaluation Reports but were used to calculate the discharge rate (natural draft cooling).	Used to calculate the discharge rate given in Site Evaluation Report – Dispersion of Radioactive Materials in Air and Water (Table 3.2-2 and Table 3.3-1), as part of the normal operating dose calculation.
				1,136 L/s@24.4°C	EPR		
2.5.14	Maximum Consumption of Raw Water	The expected maximum short-term consumptive use of water by the cooling water systems (evaporation and drift losses)	Y	1,893 L/s	AP1000	Scope of Project TSD: Table 4.5.1	Data provided for information purposes.
				7,572 L/s	AP1000		
2.5.15	Monthly Average Consumption of Raw Water	The expected normal operating consumption of water by the cooling water systems (evaporation and drift losses)	Y	1,325 L/s	AP1000	Scope of Project TSD: Table 4.5.1 Surface Water Environment Assessment of Effects TSD: Section 4.2.1	Used for the development of input parameters for surface water modelling.
				5,300 L/s	AP1000		
2.5.16	Stored Water Volume	The quantity of water stored in cooling water system impoundments, basins, tanks and/or ponds	Y	8.71E+07 L 2.61E+08 L	EPR EPR	Not used in Environmental Impact Statement or Site Evaluation Studies	N/A
2.6 Once-Through Cooling							
2.6.1	Cooling Water Discharge Temperature	Expected temperature of the cooling water at the exit of the condenser/heat exchangers	N	45.6 °C	EPR	Not used in Environmental Impact Statement or Site Evaluation Studies	N/A

* - For 3 units for EPR, or 4 units for BWRX-300, AP1000, ACR-1000, or EC6

Report

OPG Proprietary		
Document Number: N-REP-01200-10000	Usage Classification: N/A	
Sheet Number: N/A	Revision Number: R006	Page: Page 73 of 147

Title: Use of Plant Parameters Envelope to Encompass the Reactor Designs being considered for the Darlington Site

PPE Parameter			Prorated	PPE Single Unit Value PPE Pro-rated Value*	Limiting Reactor	Where Used	How Used
ID No.	Name	Definition					
2.6.2	Cooling Water Flow Rate	Total cooling water flow rate through the condenser (also the rate of withdrawal from and return to the water source)		57,100 L/s	ACR-1000	Scope of Project TSD: Table 4.5-1 Geology and Hydrogeological Environment Assessment of Environmental Effects TSD: Section 5.5 Surface Water Environment Assessment of Effects TSD: Section 4.2.1	Used for the development of input parameters for surface water modelling
			Y	228,400 L/s	ACR-1000	These values were not explicitly presented in the Site Evaluation Reports but were used to calculate the discharge rate (Once through option).	Used to calculate the discharge rate given in Site Evaluation Report – Dispersion of Radioactive Materials in Air and Water (Table 3.2-2 and Table 3.3.3-1), as part of the normal operating dose calculation.
2.6.3	Cooling Water Temperature Rise	Temperature rise across the condenser (temperature of water out minus temperature of water in)	N	15.6 °C	EPR	Aquatic Environment Assessment of Effects TSD: Executive summary, page ES-3. Also in same TSD, section 2.2.1, p.2-3, PPE values discussed. Statement re: use of 9°C in section 3.2.2.1 (Thermal Discharge), p.3-10, & section 3.3.2.4, p.3-33 (2nd prgh) Scope of Project TSD: Section 4.5.2.1, Table 4.51, p.4-37 (normal plant heat sink): Cooling Water Temperature Rise Limiting Value (°C): 15.6 (PWR), 9 (4xACR-1000, PHR) Surface Water TSD: sections 4.5.1, 4.5-2, 4.5-3, Tables 4.5-1(p.4-18), 4.5-2(p.4-19), 4.5-3 (p.4-20), footnote 4, Surface Water TSD: Section 4.5.4, pgs 4-20 to 22;	PPE values are listed with a conclusion of negligible residual thermal effects on habitat suitability and aquatic organisms. Argument/conclusion that the 9°C scenario was justified and used as the basis of the assessment. To define the input parameters for the EA assessment. 9°C temperature rise was used as input for dilution factor calculations. Use of 15.6°C max cooling water temperature increase to determine dilution factors for alternate discharge temperature.
2.6.4	Evaporation Rate	The expected (and maximum) rate at which water is lost by evaporation from the receiving water body as a result of heating in the condenser.	Y	<1,137 L/s 3,660 L/s	EPR AP1000	Not used in Environmental Impact Statement or Site Evaluation Studies	N/A
2.6.5	Heat Rejection Rate	The expected heat rejection rate to a receiving water body	Y	3,397 MW 10,191 MW	EPR EPR	Not used in Environmental Impact Statement or Site Evaluation Studies	N/A
2.7 Hybrid Cooling Towers							

* - For 3 units for EPR, or 4 units for BWRX-300, AP1000, ACR-1000, or EC6

Report

OPG Proprietary		
Document Number: N-REP-01200-10000	Usage Classification: N/A	
Sheet Number: N/A	Revision Number: R006	Page: Page 74 of 147
Title: Use of Plant Parameters Envelope to Encompass the Reactor Designs being considered for the Darlington Site		

PPE Parameter			Prorated	PPE Single Unit Value PPE Pro-rated Value*	Limiting Reactor	Where Used	How Used
ID No.	Name	Definition					
2.7.1	Acreage	The land required for cooling towers or ponds, including support facilities such as equipment sheds, basins, canals, or shoreline buffer areas	Y	16 ha 48 ha	EPR EPR	Response to JRP IR EIS 229	Comparison to land area required for mechanical draft cooling towers.
2.7.2	Height	The vertical height above finished grade of either natural draft, mechanical draft or hybrid cooling towers associated with the cooling water systems	N	50 m	EPR	Response to JRP IR EIS 229	Comparison to height of natural draft cooling towers, PPE parameter 2.5.8.
3 Ultimate Heat Sink (for accidents)							
3.1 Ambient Air Requirements							
3.1.1	Max Ambient Temperature (0% Exceedance)	Assumption used for the maximum ambient temperature in designing the Ultimate Heat Sink (UHS) system to provide heat rejection for 30 days under the assumed temperature condition	N	39°C DB	EC6	See attached table of Darlington Site Characteristic Values	Comparison to Darlington Site Characteristic Values.
3.1.2	Max Wet Bulb Temperature (0% Exceedance)	Assumption used for the maximum wet bulb temperature in designing the UHS system to provide heat rejection for 30 days under the assumed temperature condition	N	26.7°C WB (Non-Coincident)	AP1000	See attached table of Darlington Site Characteristic Values	Comparison to Darlington Site Characteristic Values.
3.1.3	Min Ambient Temperature (0% Exceedance)	Assumption used for the minimum ambient temperature in designing the UHS system to provide heat rejection for 30 days under the assumed temperature condition	N	minus 33°C	EC6	See attached table of Darlington Site Characteristic Values	Comparison to Darlington Site Characteristic Values.
3.2 UHS Heat Exchanger							

* - For 3 units for EPR, or 4 units for BWRX-300, AP1000, ACR-1000, or EC6

Report

OPG Proprietary		
Document Number: N-REP-01200-10000	Usage Classification: N/A	
Sheet Number: N/A	Revision Number: R006	Page: Page 75 of 147
Title: Use of Plant Parameters Envelope to Encompass the Reactor Designs being considered for the Darlington Site		

PPE Parameter			Prorated	PPE Single Unit Value PPE Pro-rated Value*	Limiting Reactor	Where Used	How Used
ID No.	Name	Definition					
3.2.1	Maximum Inlet Temp to UHS Heat Exchanger	The maximum temperature of safety related service water at the inlet of the UHS component cooling water heat exchanger	N	25.5°C	EC6, ACR-1000	See attached table of Darlington Site Characteristic Values	Comparison to Darlington Site Characteristic Values.
3.2.2	UHS Heat Exchanger Duty	The heat transferred to the safetyrelated service water system for rejection to the environment in UHS heat removal devices.	Y	53.3 MW 190.4 MW	EPR ACR-1000	Not used in Environmental Impact Statement or Site Evaluation Studies	N/A
3.3 Mechanical Draft Cooling Towers							
3.3.1	Acreage	The land required for cooling towers or ponds, including support facilities such as equipment sheds, basins, canals, or shoreline buffer areas	Y	3,035 m2 (0.75 acres) 9,105 m2 (2.25 acres)	EPR EPR	Not used in Environmental Impact Statement or Site Evaluation Studies	N/A
3.3.2	Approach Temperature	The difference between the cold water temperature and the ambient wet bulb temperature.	N	6.3°C	EC6, ACR-1000	Not used in Environmental Impact Statement or Site Evaluation Studies	N/A
3.3.3	Blowdown Constituents and Concentrations	The maximum expected concentrations for anticipated constituents in the cooling water systems blowdown to the receiving water body	N	Refer to Table 4.7	EPR, AP1000, EC6, ACR-1000	Scope of Project TSD: Table 4.5-4 (some of the values are slightly different from the PPE document due to rounding)	Data provided for information purposes.
3.3.4	Blowdown Flow Rate	The normal (and maximum) flow rate of the blowdown stream from the cooling water systems to the receiving water body for closed system designs	Y Y	18.9 L/s expected 48 L/s max 56.7 L/s expected 192 L/s max	EPR EC6 EPR EC6	Scope of Project TSD: Table 4.5-1	Data provided for information purposes.

* - For 3 units for EPR, or 4 units for BWRX-300, AP1000, ACR-1000, or EC6

Report

OPG Proprietary		
Document Number: N-REP-01200-10000	Usage Classification: N/A	
Sheet Number: N/A	Revision Number: R006	Page: Page 76 of 147

Title: Use of Plant Parameters Envelope to Encompass the Reactor Designs being considered for the Darlington Site

PPE Parameter			Prorated	PPE Single Unit Value PPE Pro-rated Value*	Limiting Reactor	Where Used	How Used
ID No.	Name	Definition					
3.3.5	Blowdown Temperature	The maximum expected blowdown temperature at the point of discharge to the receiving water body	N	35 °C	EPR	Scope of Project TSD: Section 4.5.2.1, Table 4.5-1, page 4-37 includes Blowdown Flow Rate (L/s@°C) – temperature specified for ultimate heat sink for mechanical draft cooling: at 35°C for PWR limiting value , and 30.3°C for the ACR 1000, 4 units PHR limiting value	Data provided for information purposes.
3.3.6	Cycles of Concentration	The ratio of total dissolved solids in the cooling water blowdown streams to the total dissolved solids in the makeup water streams	N	4	EPR, EC6, AP1000, ACR-1000	Not used in Environmental Impact Statement or Site Evaluation Studies	N/A
3.3.7	Evaporation Rate	The expected (and maximum) rate at which water is lost by evaporation from the cooling water systems	Y Y	18.9 L/s expected 44.2 L/s maximum 66 L/s expected 176.8 L/s maximum	EPR ACR-1000 EC6 ACR-1000	Not used in Environmental Impact Statement or Site Evaluation Studies	N/A
3.3.8	Height	The vertical height above finished grade of either natural draft or mechanical draft cooling towers associated with the cooling water systems	N	29.3 m	EPR	Not used in Environmental Impact Statement or Site Evaluation Studies	N/A
3.3.9	Makeup Flow Rate	The expected (and maximum) rate of removal of water from a natural source to replace water losses from closed cooling water systems	Y	37.9 L/s expected 92 L/s maximum 113.7 L/s expected 366 L/s maximum	EPR EC6 EPR EC6	Not used in Environmental Impact Statement or Site Evaluation Studies	N/A
3.3.10	Noise	The maximum expected sound level produced by operation of cooling towers, measured at 1000 feet from the noise source	N	55 dBa at 305 m	EC6, ACR-1000	Not used in Environmental Impact Statement or Site Evaluation Studies	N/A
3.3.11	Cooling Tower Temperature Range	The temperature difference between the cooling water entering and leaving the towers	N	11 °C	EC6, ACR-1000	Not used in Environmental Impact Statement or Site Evaluation Studies	N/A

* - For 3 units for EPR, or 4 units for BWRX-300, AP1000, ACR-1000, or EC6

Report

OPG Proprietary		
Document Number: N-REP-01200-10000	Usage Classification: N/A	
Sheet Number: N/A	Revision Number: R006	Page: Page 77 of 147
Title: Use of Plant Parameters Envelope to Encompass the Reactor Designs being considered for the Darlington Site		

PPE Parameter			Prorated	PPE Single Unit Value PPE Pro-rated Value*	Limiting Reactor	Where Used	How Used
ID No.	Name	Definition					
3.3.12	Cooling Water Flow Rate	The total cooling water flow rate through the condenser / heat exchangers	Y	3,870 L/s 15,480 L/s	EC6 EC6	Not used in Environmental Impact Statement or Site Evaluation Studies	N/A
3.3.13	Heat Rejection Rate (blowdown)	The expected heat rejection rate to a receiving water body, expressed as flow rate in litres per second at a temperature in degrees Celsius	Y	18.9 L/s @35°C	EPR	Scope of Project TSD: Table 4.5-1	Data provided for information purposes.
				56.7 L/s@35°C	EPR	These values were not explicitly presented in the Site Evaluation Reports but were used to calculate the discharge rate (mechanical draft cooling)	Used to calculate the discharge rate given in Site Evaluation Report – Dispersion of Radioactive Materials in Air and Water (Table 3.2-2 and Table 3.3.3-1), as part of the normal operating dose calculation.
3.3.14	Maximum Consumption of Raw Water	The expected maximum short-term consumptive use of water by the cooling water systems (evaporation and drift losses)	Y	46 L/s 184 L/s	EC6 EC6	Not used in Environmental Impact Statement or Site Evaluation Studies	N/A
3.3.15	Monthly Average Consumption of Raw Water	The expected normal operating consumption of water by the cooling water systems (evaporation and drift losses)	Y	28.4 L/s 85.2 L/s	EPR EPR	Scope of Project TSD: Table 4.5.1	Used for the development of input parameters for surface water modelling
3.3.16	Stored Water Volume	The quantity of water stored in cooling water system impoundments, basins, tanks and/or ponds	Y	1.2E+08 L 4.8E+08 L	EC6 EC6	Not used in Environmental Impact Statement or Site Evaluation Studies	N/A
3.4 Once-Through Cooling							
3.4.1	Cooling Water Discharge Temperature	Expected temperature of the cooling water at the exit of the UHS system	N	57.2 °C	EPR	Not used in Environmental Impact Statement or Site Evaluation Studies	N/A
3.4.2	Cooling Water Flow Rate	Total cooling water flow rate through the UHS (also the rate of withdrawal from and return to the water source)	Y	3,870 L/s	EC6	Scope of Project TSD: Table 4.5-1	Data provided for information purposes.
				15,480 L/s	EC6	These values were not shown in the Site Evaluation Reports but were used to calculate the discharge rate (Once through option).	Used to calculate the discharge rate given in Site Evaluation Report – Dispersion of Radioactive Materials in Air and Water (Table 3.2-2 and Table 3.3.3-1), as part of the normal operating dose calculation.

* - For 3 units for EPR, or 4 units for BWRX-300, AP1000, ACR-1000, or EC6

Report

OPG Proprietary		
Document Number: N-REP-01200-10000	Usage Classification: N/A	
Sheet Number: N/A	Revision Number: R006	Page: Page 78 of 147
Title: Use of Plant Parameters Envelope to Encompass the Reactor Designs being considered for the Darlington Site		

PPE Parameter			Prorated	PPE Single Unit Value PPE Pro-rated Value*	Limiting Reactor	Where Used	How Used
ID No.	Name	Definition					
3.4.3	Cooling Water Temperature Rise	Temperature rise across the heat exchangers cooled by the UHS (temperature of water out minus temperature of water in)	N	22.2 °C	EPR	Not used in Environmental Impact Statement or Site Evaluation Studies	N/A
3.4.4	Minimum Essential Flow Rate	Minimum flow required to maintain required heat removal capacity under design-basis accident conditions	Y	3,870 L/s 15,480 L/s	EC6 EC6	Not used in Environmental Impact Statement or Site Evaluation Studies	N/A
3.4.5	Evaporation Rate	The expected (and maximum) rate at which water is lost by evaporation from the UHS as a result of heat rejection from the plant	Y Y	9.5 L/s expected 25 L/s max 38 L/s expected 100 L/s max	EC6, ACR-1000	Not used in Environmental Impact Statement or Site Evaluation Studies	N/A
3.4.6	Heat Rejection Rate	The expected heat rejection rate to the UHS	Y	58.6 MW 190.4 MW	EPR ACR-1000	Not used in Environmental Impact Statement or Site Evaluation Studies	N/A
4 Containment Heat Removal System (Post Accident)							
4.1 Ambient Air Requirements							
4.1.1	Maximum Ambient Air Temperature (0% Exceedance)	Assumed maximum ambient temperature used in designing the containment heat removal system	N	43.0°C DB	EPR, ACR-1000	See attached table of Darlington Site Characteristic Values	Comparison to Darlington Site Characteristic Values.
4.1.2	Minimum Ambient Temperature (0% Exceedance)	Assumed minimum ambient temperature used in designing the containment heat removal system	N	minus 33°C	EC6	See attached table of Darlington Site Characteristic Values	Comparison to Darlington Site Characteristic Values.
5 Potable Water/Sanitary Waste System							
5.1 Discharge to Site Water Bodies							

* - For 3 units for EPR, or 4 units for BWRX-300, AP1000, ACR-1000, or EC6

Report

OPG Proprietary		
Document Number: N-REP-01200-10000	Usage Classification: N/A	
Sheet Number: N/A	Revision Number: R006	Page: Page 79 of 147
Title: Use of Plant Parameters Envelope to Encompass the Reactor Designs being considered for the Darlington Site		

PPE Parameter			Prorated	PPE Single Unit Value PPE Pro-rated Value*	Limiting Reactor	Where Used	How Used
ID No.	Name	Definition					
5.1.1	Flow Rate	The expected (and maximum) effluent flow rate from the potable and sanitary waste water systems to the receiving water body	Y Y	1.5 L/s expected 4.38 L/s max 6.0 L/s expected 17.52 L/s max	ACR-1000 AP1000 ACR-1000 AP1000	Socio Economic Effects Assessment TSD: Section 3.3.3.2 Scope of Project TSD: Table 4.5.1, Sections 4.5.4.1 and 4.5.4.2 Malfunctions and Accidents TSD: Section 3.7.1	Effects on Municipal (Table 5 & Table 7) Infrastructure and Services Potable Water/Sanitary Waste (L/s) - Monthly Average Loss of Domestic Water Supply
5.2 Raw Water Requirements							
5.2.1	Maximum Use	The maximum short-term rate of withdrawal from the water source for the potable and sanitary waste water systems	Y	4.38 L/s 17.5 L/s	AP1000 AP1000	Not used in Environmental Impact Statement or Site Evaluation Studies	N/A
5.2.2	Monthly Average Use	The average rate of withdrawal from the water source for the potable and sanitary waste water systems	Y	1.5 L/s 6 L/s	ACR-1000 ACR-1000	Scope of Project TSD: Table 4.5.1	Data provided for information purposes.
6 Demineralized Water System							
6.1 Discharge to Surface Water Bodies							
6.1.1	Flow Rate	The expected (and maximum) effluent flow rate from the demineralized system to the receiving water body	Y Y	9 L/s expected 10.5 L/s max 36 L/s expected 42 L/s max	ACR-1000	Scope of Project TSD: Table 4.5.1, Section 4.5.2.4 These values were not explicitly presented in the Site Evaluation Reports but were used to calculate the discharge rate (Once through option, natural draft cooling and mechanical draft cooling).	Data provided for information purposes Used to calculate the discharge rate given in Site Evaluation Report – Dispersion of Radioactive Materials in Air and Water (Table 3.2-2 and Table 3.3.3-1), as part of the normal operating use calculation.
6.2 Raw Water Requirements							
6.2.1	Maximum Use	The maximum short-term rate of withdrawal	Y	34.07 L/s 136.28 L/s	AP1000	Scope of Project TSD: Table 4.5.1	Data provided for information purposes.

* - For 3 units for EPR, or 4 units for BWRX-300, AP1000, ACR-1000, or EC6

Report

OPG Proprietary		
Document Number: N-REP-01200-10000	Usage Classification: N/A	
Sheet Number: N/A	Revision Number: R006	Page: Page 80 of 147
Title: Use of Plant Parameters Envelope to Encompass the Reactor Designs being considered for the Darlington Site		

PPE Parameter			Prorated	PPE Single Unit Value PPE Pro-rated Value*	Limiting Reactor	Where Used	How Used
ID No.	Name	Definition					
		from the water source for the demineralized water system					
6.2.2	Monthly Average Use	The average rate of withdrawal from the water source for the demineralized water system	Y	18 L/s 72 L/s	ACR-1000	Scope of Project TSD: Table 4.5.1	Data provided for information purposes.
7 Fire Protection System							
7.1 Raw Water Requirements							
7.1.1	Maximum Use	The maximum short-term rate of withdrawal from the water source for the fire protection water system	Y	127 L/s 508 L/s	BWRX-300	Scope of Project TSD: Table 4.5.1, Section 4.5.4.1 Socio Economic Effects Assessment TSD: Section 3.3.3.2	Fire Water Protection - Maximum Use Effects on Municipal Infrastructure and Services
7.1.2	Monthly Average Use	The average rate of withdrawal from the water source for the fire protection water system	Y	0.315 L/s 1.26 L/s	AP1000	Scope of Project TSD: Table 4.5.1, Section 4.5.4.1	Data provided for information purposes.
					AP1000	These values were not explicitly presented in the Site Evaluation Reports but were used to calculate the discharge rate (Once through option, natural draft cooling and mechanical draft cooling).	Used to calculate the discharge rate given in Site Evaluation Report – Dispersion of Radioactive Materials in Air and Water (Table 3.2-2 and Table 3.3.3-1), as part of the normal operating dose calculation.
7.1.3	Stored Water Volume	The quantity of water stored in fire protection system impoundments, basins or tanks	Y	4E+06 L 4E+06 L	BWRX-300	Scope of Project TSD: Table 4.5-1	Data provided for information purposes.
8 Miscellaneous Drain							
8.1 Discharge to Site Water Bodies							
8.1.1	Flow Rate	The expected (and maximum) effluent flow rate from miscellaneous drains to the receiving water body	Y		AP1000, ACR-1000	Scope of Project TSD: Table 4.5.1, Section 4.5.2.5 Geological and Hydrogeological Environmental Effects TSD: Section 3.2.3.7	Data provided for information purposes
			Y		AP1000,		

* - For 3 units for EPR, or 4 units for BWRX-300, AP1000, ACR-1000, or EC6

Report

OPG Proprietary		
Document Number: N-REP-01200-10000	Usage Classification: N/A	
Sheet Number: N/A	Revision Number: R006	Page: Page 81 of 147

Title: Use of Plant Parameters Envelope to Encompass the Reactor Designs being considered for the Darlington Site

PPE Parameter			Prorated	PPE Single Unit Value PPE Pro-rated Value*	Limiting Reactor	Where Used	How Used
ID No.	Name	Definition					
				1.6 L/s expected	ACR-1000	These values were not explicitly presented in the Site Evaluation Reports but were used to calculate the discharge rate (Once through option, natural draft cooling and mechanical draft cooling).	Used to calculate the discharge rate given in Site Evaluation Report – Dispersion of Radioactive Materials in Air and Water (Table 3.2-2 and Table 3.3.3-1), as part of the normal operating dose calculation.
				3.2 L/s max	AP1000, ACR-1000		
				6.4 L/s expected	AP1000, ACR-1000		
				12.8 L/s max			
9 Airborne Effluent Release							
9.1 Atmospheric Dispersion (CHI/Q) (Accident)							
9.1.1	Exclusion Area Boundary (EAB)	Radius of the exclusion area boundary assumed in dose calculations	N	500 m	EPR, EC6, AP1000, ACR-1000	Not used in Environmental Impact Statement or Site Evaluation Studies	N/A
9.1.2	Low Population Zone (LPZ)	Radius of the low population zone boundary assumed in dose calculations	N	3,220 m	AP1000	Not used in Environmental Impact Statement or Site Evaluation Studies	N/A
9.1.3	0-2h @ EAB	The atmospheric dispersion coefficients used in the design safety analysis to estimate dose consequences of ambient airborne releases	N	1.00E-03 s/m3	EPR, EC6 AP1000, ACR-1000	Not used in Environmental Impact Statement or Site Evaluation Studies	N/A
9.1.4	0-8h @ LPZ			5.00E-04 s/m3	AP1000		
9.1.5	8-24h @ LPZ			3.00E-04 s/m3	AP1000		
9.1.6	1-4d @ LPZ			1.50E-04 s/m3	AP1000		
9.1.7	4-30d @ LPZ			8.00E-05 s/m3	AP1000		
9.2 Atmospheric Dispersion (CHI/Q) (Annual Average)							
9.2	Atmospheric Dispersion (CHI/Q) (Annual Average)	The atmospheric dispersion coefficients used in the safety analysis for the dose consequences of normal airborne releases	N	2.00E-05 s/m3	EC6, AP1000, ACR-1000	Not used in Environmental Impact Statement or Site Evaluation Studies	N/A
9.3 Dose Consequence							

* - For 3 units for EPR, or 4 units for BWRX-300, AP1000, ACR-1000, or EC6

Report

OPG Proprietary		
Document Number: N-REP-01200-10000	Usage Classification: N/A	
Sheet Number: N/A	Revision Number: R006	Page: Page 82 of 147

Title:
Use of Plant Parameters Envelope to Encompass the Reactor Designs being considered for the Darlington Site

PPE Parameter			Prorated	PPE Single Unit Value PPE Pro-rated Value*	Limiting Reactor	Where Used	How Used
ID No.	Name	Definition					
9.3.1	Normal	The estimated design radiological dose consequences due to gaseous releases from normal operation of plant	Y	CNSC Nuclear Safety & Control Regulations; CNSC Radiation Protection Regulations; CNSC G-129; CSA N288.1	EPR, AP1000, EC6, ACR-1000	Radiation and Radioactivity Assessment of Environmental Effects TSD: Sections 3.6.2 & 3.7.2.1 Radiation and Radioactivity Existing Conditions TSD: Table 2.3.2, Sections 3.3.5 & 3.3.6 Human Health TSD: Section 4.4.3.1 & 4.4.3.2 Nuclear Waste Management TSD: Sections ES-3.3, ES-4, 6.6.2, 6.7.2 and 6.8.2 Scope of Project TSD: Section 4.5.10	This PPE value was considered but was not used in the assessment
9.3.2	Normal, Limiting	The limiting (i.e., worst case) radiological dose consequences due to gaseous releases from normal operation of plant	Y	1.00 mSv/y 1.00 mSv/y	EPR, AP1000, EC6, ACR-1000	Radiation & Radioactivity Assessment of Environmental Effects TSD: Sections 3.6.2 & 3.7.2.1 Radiation and Radioactivity Existing Conditions TSD: Sections 2.3.2, 3.3.5 & 3.3.6 Human Health TSD: Sections 4.4.3.1 & 4.4.3.2 Social Economic TSD: Section 3.5.6 Nuclear Waste Management TSD: Sections ES-3.3, ES-4, 6.6.2, 6.7.2 & 6.8.2 Scope of Project TSD: Section 4.5.10	This PPE value was considered but not used in the assessment
9.3.3	Design Basis Accident	The limiting (i.e., worst case) radiological dose consequences due to gaseous releases from postulated accidents	N	<20 mSv for a DBA per RD-337	EPR, AP1000, EC6, ACR-1000	Not used in EIS or SES documents. See the Site Boundary Conditions report and the Exclusion Zone report for related discussion	N/A
9.3.4	Severe Accidents (Beyond Design Basis Accidents)	The limiting (i.e., worst case) radiological dose consequences due to gaseous releases from severe accidents	N	N/A. RD-337 safety goals apply.	EPR, AP1000, EC6, ACR-1000	Not used in Environmental Impact Statement or Site Evaluation Studies	N/A
9.4 Release Point							
9.4.1	Configuration	The orientation of the release point discharge flow	N	Vertical and horizontal	EC6, ACR-1000	Not used in Environmental Impact Statement or Site Evaluation Studies	N/A
9.4.2	Elevation (Normal		N	35 m	BWRX-300	Scope of Project TSD, Section 4.4 Atmospheric Environment Assessment of Effects TSD, Appendix C	Reactor Building and Air Release Characteristics, Input to atmospheric dispersion modelling

* - For 3 units for EPR, or 4 units for BWRX-300, AP1000, ACR-1000, or EC6

Report

OPG Proprietary		
Document Number: N-REP-01200-10000	Usage Classification: N/A	
Sheet Number: N/A	Revision Number: R006	Page: Page 83 of 147

Title: Use of Plant Parameters Envelope to Encompass the Reactor Designs being considered for the Darlington Site

PPE Parameter			Prorated	PPE Single Unit Value PPE Pro-rated Value*	Limiting Reactor	Where Used	How Used
ID No.	Name	Definition					
	Operation)	The elevation above finished grade of the release point for routine operational releases				Site Evaluation Report – Dispersion of Radioactive Materials in Air and Water: Page 52 (Table 3.1-2) Site Evaluation Report – Nuclear Safety Considerations, Page 66 (Section 5.2.1)	Input to atmospheric dispersion modelling. Input to atmospheric dispersion modelling.
9.4.3	Elevation (Design Basis Accident)	The elevation above finished grade of the release point for accident sequence releases	N	Ground Level	EPR, EC6 AP1000, ACR-1000	Malfunctions and Accidents TSD: Appendices B and C	Input for dispersion modelling for Malfunctions and Accidents
9.4.4	Minimum Distance to Site Boundary	The minimum lateral distance from the release point to the site boundary	N	500 m	EPR, EC6 AP1000, ACR-1000	Malfunctions and Accidents TSD: Section 4.2.8	Distance from release point to closest residences.
9.4.5	Temperature	The temperature of the airborne effluent stream at the release point	N	48.9°C normal, 148.9°C worst case	EPR	Site Evaluation Report – Dispersion of Radioactive Materials in Air and Water: Page 52 (Table 3.1-2) Site Evaluation Report – Nuclear Safety Considerations Page 66 (Section 5.2.1)	To calculate doses during normal operations. To calculate doses during normal operations.
9.4.6	Volumetric Flow Rate	The volumetric flow rate of the airborne effluent stream at the release point	Y	114,447 L/s 277,778 L/s	EPR ACR-1000	Site Evaluation Report – Dispersion of Radioactive Materials in Air and Water: Page 52 (Table 3.1-2) Site Evaluation Report – Nuclear Safety Considerations Page 66 (Section 5.2.1)	To calculate doses during normal operations. To calculate doses during normal operations.
9.5 Source Term							
9.5.1	Gaseous (Normal) - Carbon-14 - Noble Gases - Iodine-131 - Particulates	The annual activity, by isotope, contained in routine plant airborne effluent streams	Y	Refer to Table 4.1	EPR	Scope of Project TSD: Section 4.1.3.1, Table 4.1.1 (ACR), Section 4.2.3, Table 4.2.1 (EPR), Section 4.3.3, Table 4.3.1 (AP1000) Radiation and Radioactivity Environmental Effects TSD: Appendix D Ecological Risk Assessment and Assessment of Effects on Non-human Biota TSD	To define the maximum radiological releases other than tritium under normal operations. To calculate the dose to members of the public. To calculate the dose to non-human biota.
						Site Evaluation Report – Dispersion of Radioactive Materials in Air and Water: Page 51 (Table 3.1-1) Site Evaluation Report – Nuclear Safety Considerations, Page 63 (Section 5.2.1)	To calculate doses during normal operations. To calculate doses during normal operations.
				Refer to Table 4.2	EPR		

* - For 3 units for EPR, or 4 units for BWRX-300, AP1000, ACR-1000, or EC6

Report

OPG Proprietary		
Document Number: N-REP-01200-10000	Usage Classification: N/A	
Sheet Number: N/A	Revision Number: R006	Page: Page 84 of 147
Title: Use of Plant Parameters Envelope to Encompass the Reactor Designs being considered for the Darlington Site		

PPE Parameter			Prorated	PPE Single Unit Value PPE Pro-rated Value*	Limiting Reactor	Where Used	How Used
ID No.	Name	Definition					
9.5.2	Gaseous (Design Basis Accident)	The activity, by isotope, contained in post-accident airborne effluents	N	Limiting source terms will be determined during the detailed safety analysis in future licensing stages, in accordance with regulatory documents such as RD-337.	EPR, EC6 AP1000, ACR-1000	Not used in EIS or SES documents. See the Site Boundary Conditions report and the Exclusion Zone report for related discussion	N/A
9.5.3	Tritium	The annual activity of tritium contained in routine plant airborne effluent streams	Y	245 TBq/y 980 TBq/y	EC6 EC6	Scope of Project TSD: Sections 4.2.3 and 4.3.3 Radiation and Radioactivity Environmental Effects TSD: Appendix D Ecological Risk Assessment and Assessment of Effects on Non-human Biota TSD	To define the maximum radiological releases under normal operations. PPE value for ACR-1000 airborne tritium was not used. It was assumed in the EA that tritium removal from heavy water would not take place. The bounding airborne tritium release assumed was 4.8E+14 Bq/y. To calculate the dose to members of the public. To calculate the dose to non-human biota.
10 Liquid Radwaste System							
10.1 Dose Consequence							
10.1.1	Normal	The design radiological dose consequences due to liquid effluent releases from normal operation of the plant	Y	CNSC Nuclear Safety & Control Regulations; CNSC Radiation Protection Regulations; CNSC G-129; CSA N288.1	EPR, AP1000, EC6, ACR-1000	Site Evaluation Report – Nuclear Safety Considerations Page 63 (Section 5.2.1)	To calculate doses during normal operations.
10.1.2	Design Basis Accident	The design radiological dose consequences due to liquid effluent releases from postulated accidents	N	CNSC Nuclear Safety & Control Regulations; CNSC Radiation Protection Regulations; CNSC G-129; CSA N288.1	EPR, AP1000, EC6, ACR-1000	Not used in Environmental Impact Statement or Site Evaluation Studies	N/A
10.2 Release Point							

* - For 3 units for EPR, or 4 units for BWRX-300, AP1000, ACR-1000, or EC6

Report

OPG Proprietary		
Document Number: N-REP-01200-10000	Usage Classification: N/A	
Sheet Number: N/A	Revision Number: R006	Page: Page 85 of 147
Title: Use of Plant Parameters Envelope to Encompass the Reactor Designs being considered for the Darlington Site		

PPE Parameter			Prorated	PPE Single Unit Value PPE Pro-rated Value*	Limiting Reactor	Where Used	How Used
ID No.	Name	Definition					
10.2.1	Flow Rate	The discharge (including minimum dilution flow, if any) of liquid potentially radioactive effluent streams from plant systems to the receiving water body	Y	0.6 L/s, 2.15 m3/h	ACR-1000	Scope of Project TSD: Sections 4.1.3.2, 4.2.3 and 4.3.3	Data provided for information purposes.
				2.4 L/s, 8.60 m3/h	ACR-1000	These values were not found in the Site Evaluation Reports but were used to calculate the discharge rate (Once through option, natural draft cooling and mechanical draft cooling). Site Evaluation Report – Nuclear Safety Considerations, Page 66 (Section 5.2.1)	Used to calculate the discharge rate given in Site Evaluation Report – Dispersion of Radioactive Materials in Air and Water (Table 3.2-2 and Table 3.3.3-1), as part of the normal operating dose calculation. To calculate doses during normal operations.
10.3 Source Term							
10.3.1	Liquid	The annual activity, by isotope, contained in routine plant liquid effluent streams	Y	Refer to Table 4.3	EC6	Scope of Project TSD: Sections 4.2.3 Table 4.2-2 and 4.3.3 Table 4.3-2 Radiation and Radioactivity Environmental Effects TSD: Appendix D Table D.2-1 Ecological Risk Assessment and Assessment of Effects on Non-human Biota TSD	To define the maximum radiological releases other than tritium under normal operations. To calculate the dose to members of the public. To calculate the dose to non-human biota
				Refer to Table 4.4		Site Evaluation Report – Dispersion of Radioactive Materials in Air and Water: Page 53 (Table 3.2-1)	To calculate doses during normal operations.
10.3.2	Tritium	The annual activity of tritium contained in routine plant liquid effluent streams	Y	400 TBq/y	EC6	Scope of Project TSD: Sections 4.2.3 and 4.3.3	To define the maximum radiological releases under normal operations. PPE value for ACR-1000 waterborne tritium was not used. It was assumed in the EA that tritium removal from heavy water would not take place. The bounding airborne tritium release assumed was 1.4E+15 Bq/y. To calculate the dose to members of the public.
				1600 TBq/y		Radiation and Radioactivity Environmental Effects TSD: Appendix D Ecological Risk Assessment and Assessment of Effects on Non-human Biota TSD	To calculate the dose to non-human biota.

* - For 3 units for EPR, or 4 units for BWRX-300, AP1000, ACR-1000, or EC6

Report

OPG Proprietary		
Document Number: N-REP-01200-10000	Usage Classification: N/A	
Sheet Number: N/A	Revision Number: R006	Page: Page 86 of 147
Title: Use of Plant Parameters Envelope to Encompass the Reactor Designs being considered for the Darlington Site		

PPE Parameter			Prorated	PPE Single Unit Value PPE Pro-rated Value*	Limiting Reactor	Where Used	How Used
ID No.	Name	Definition					
					EC6	Site Evaluation Report – Dispersion of Radioactive Materials in Air and Water: Page 53 (Table 3.2-1) Site Evaluation Report – Nuclear Safety Considerations Page 66 (Section 5.2.1) and Page 69 (Section 5.3.1)	To calculate doses during normal operations. To calculate doses during normal operations.
11 Solid Radwaste System							
11.1 Acreage							
11.1.1	Low Level Radwaste Storage	The land usage required to provide onsite storage of low level radioactive wastes	Y	450 m2 1,440 m2	EC6 ACR-1000	Not used in Environmental Impact Statement or Site Evaluation Studies	N/A
11.2 Solid Radwaste							
11.2.1	Activity	The annual activity, by isotope, contained in solid radioactive wastes generated during routine plant operations	Y	Refer to Table 4.5 Refer to Table 4.6	AP1000	Nuclear Waste Management TSD: Table A-1	Used in the development of the values reported in Table A-1
11.2.3	Volume	The expected volume of solid radioactive wastes generated during routine plant operations	Y	224.5 m3/y 673.5 m3/y	EPR EPR	Nuclear Waste Management TSD: Tables 3.2-1, A1 and A-3	This PPE value was considered but not used in the assessment
12 Fuel							
12.1 Fuel Design							
12.1.1	Fuel Enrichment	The enrichment of the fuel	N	5 wt% U235	EPR	Scope of Project TSD: Sections 4.1.5.1, 4.2.5.1, 4.5.3.1	Data provided for information purposes.
12.1.2	Mass of fuel in Core	The total mass of uranium dioxide in the core	Y	146.26 Mg 460 Mg	EPR ACR-1000	Not used in Environmental Impact Statement or Site Evaluation Studies	N/A
12.1.3	Mass of Zirconium Alloys in Core	The total mass of all zirconium alloys in the core	Y	43 Mg 129 Mg	EPR EPR	Not used in Environmental Impact Statement or Site Evaluation Studies	N/A
12.2 Discharged Fuel							
						Nuclear Waste Management TSD	This data was not presented in the

* - For 3 units for EPR, or 4 units for BWRX-300, AP1000, ACR-1000, or EC6

Report

OPG Proprietary		
Document Number: N-REP-01200-10000	Usage Classification: N/A	
Sheet Number: N/A	Revision Number: R006	Page: Page 87 of 147
Title: Use of Plant Parameters Envelope to Encompass the Reactor Designs being considered for the Darlington Site		

PPE Parameter			Prorated	PPE Single Unit Value PPE Pro-rated Value*	Limiting Reactor	Where Used	How Used
ID No.	Name	Definition					
12.2.1	Total Mass	Total mass of fuel used during the lifetime of the reactor	Y	7,860 Mg 31,440 Mg	EC6 EC6		Nuclear Waste Management TSD but was used to determine the number of Dry Storage Containers required, and therefore the number of buildings required for interim storage.
12.3 Spent Fuel Storage Pool							
12.3.1	Pool Capacity	Number of years of reactor operation that spent fuel storage pool can accommodate all fuel discharged from the core	N	9+ y	EC6	Not used in Environmental Impact Statement or Site Evaluation Studies	N/A
12.3.2	Pool Volume	Volume of spent fuel storage pool	Y	4,928 m3 19,712 m3	ACR-1000 ACR-1000	Not used in Environmental Impact Statement or Site Evaluation Studies	N/A
12.3.3	Annual Dose	Annual dose at the EAB due to operation of the spent fuel storage pool	Y	approximately 0.2 µSv/y approximately 0.2 µSv/y	EC6 EC6	Not used in Environmental Impact Statement or Site Evaluation Studies	N/A
12.4 Spent Fuel Dry Storage							
12.4.1	Acreage	The land usage required to provide onsite dry storage of spent fuel for the expected plant lifetime, including the fenced off area necessary to provide an acceptable radiation protection and security zone	Y	60,703 m2 (15 acres) 242,811 m2 (60 acres)	AP1000 AP1000	Not used in Environmental Impact Statement or Site Evaluation Studies	N/A
12.4.2	Storage Capacity	The years of plant operation for which spent fuel dry storage should be provided without taking credit for capacity in the spent fuel pool	N	50 y	ACR-1000	Not used in Environmental Impact Statement or Site Evaluation Studies	N/A
12.4.3	Annual Dose	Annual dose at the EAB due to operation of the spent fuel dry storage area	N	<20 µSv/y	EPR	Scope of Project for EA Purposes TSD: Section 4.5.7	This PPE value was considered but not used in the assessment
13 Auxiliary Boiler Systems							

* - For 3 units for EPR, or 4 units for BWRX-300, AP1000, ACR-1000, or EC6

Report

OPG Proprietary		
Document Number: N-REP-01200-10000	Usage Classification: N/A	
Sheet Number: N/A	Revision Number: R006	Page: Page 88 of 147
Title: Use of Plant Parameters Envelope to Encompass the Reactor Designs being considered for the Darlington Site		

PPE Parameter			Prorated	PPE Single Unit Value PPE Pro-rated Value*	Limiting Reactor	Where Used	How Used
ID No.	Name	Definition					
13.1	Exhaust Elevation	The height above finished plant grade at which the flue gas effluents are released to the environment	N	33 m	EC6, ACR-1000	Scope of Project for EA Purposes TSD: Section 4.5.3 and Table 4.5-6 Atmospheric Environment Assessment of Effects TSD, Appendix C	To define the input parameters for the EA assessment Input to atmospheric dispersion modelling
13.2	Flue Gas Effluents	The expected combustion products and anticipated quantities released to the environment due to operation of the auxiliary boilers, diesel engines and gas turbines	Y	Refer to Table 4.8 Refer to Table 4.9	AP1000	Not used in Environmental Impact Statement or Site Evaluation Studies	N/A
13.3	Fuel Type	The type of fuel oil required for proper operation of the auxiliary boilers, diesel engines and gas turbines	N	No. 2 Fuel Oil	EPR, AP1000, EC6, ACR-1000	Scope of Project for EA Purposes TSD: Table 4.5-6 Atmospheric Environment Assessment of Effects TSD, Appendix C	To define the input parameters for the EA assessment Input to atmospheric dispersion modelling
13.4	Heat Input Rate	The average heat input rate due to the periodic operation of the auxiliary boilers	Y	45.72 MW 182.88 MW	AP1000 AP1000	Scope of Project for EA Purposes TSD: Table 4.56 Atmospheric Environment Assessment of Effects TSD, Appendix C	To define the input parameters for the EA assessment Input to atmospheric dispersion modelling
14 Heating, Ventilation and Air Conditioning System							
14.1 Ambient Air Requirements							
14.1.1	Non-safety HVAC max ambient temp (1% exceedance)	Assumption used for the maximum ambient temperature that will be exceeded no more than 1% of the time, to design the non-safety HVAC systems	N	34°C DB	EC6	See attached table of Darlington Site Characteristic Values	Comparison to Darlington Site Characteristic Values.
14.1.2	Non-safety HVAC min ambient temp (1% exceedance)	Assumption used for the minimum ambient temperature that will be exceeded no more than 1% of the time, to design the non-safety HVAC systems	N	minus 24°C	EC6	See attached table of Darlington Site Characteristic Values	Comparison to Darlington Site Characteristic Values.
14.1.3	Safety HVAC max ambient temp (0% Exceedance)	Assumption used for the maximum ambient temperature that will never be	N	39°C DB	EC6	See attached table of Darlington Site Characteristic Values	Comparison to Darlington Site Characteristic Values.

* - For 3 units for EPR, or 4 units for BWRX-300, AP1000, ACR-1000, or EC6

Report

OPG Proprietary		
Document Number: N-REP-01200-10000	Usage Classification: N/A	
Sheet Number: N/A	Revision Number: R006	Page: Page 89 of 147
Title: Use of Plant Parameters Envelope to Encompass the Reactor Designs being considered for the Darlington Site		

PPE Parameter			Prorated	PPE Single Unit Value PPE Pro-rated Value*	Limiting Reactor	Where Used	How Used
ID No.	Name	Definition					
		exceeded, to design the safety-related HVAC systems					
14.1.4	Safety HVAC min ambient temp (0% Exceedance)	Assumption used for the minimum ambient temperature that will never be exceeded, to design the safety-related HVAC systems	N	minus 33°C	EC6	See attached table of Darlington Site Characteristic Values	Comparison to Darlington Site Characteristic Values.
14.1.5	Vent System max ambient temp (5% exceedance)	Assumption used for the maximum ambient temperature that will be exceeded no more than 5% of the time to design the non-HVAC ventilation systems	N	27.3°C DB, 20.1°C WB coincident, 22.3°C WB noncoincident (5% exceedance)	EC6	See attached table of Darlington Site Characteristic Values	Comparison to Darlington Site Characteristic Values.
14.1.6	Vent System min ambient temp (5% exceedance)	Assumption used for the minimum ambient temperature that will be exceeded no more than 5% of the time to design the non-HVAC ventilation systems	N	minus 12°C	EC6	See attached table of Darlington Site Characteristic Values	Comparison to Darlington Site Characteristic Values.
15 Onsite/Offsite Electrical Power Systems							
15.1 Acreage							
15.1.1	Switchyard	The land usage required for the high voltage switchyard used to connect the plant to the transmission grid	Y	97,000 m2 (24 acres) 291,000 m2 (72 acres)	EPR EPR	Scope of Project for EA Purposes TSD: Section 4.5.3.1	This PPE value was considered but not used in the assessment
16 Standby Power							
16.1 Diesel							
16.1.1	Diesel Capacity	The capacity of diesel engines used for generation of standby electrical power	Y	40,800 kW total 122,400 kW total	EPR EPR	Scope of Project for EA Purposes TSD: Section 4.5.3.3 Atmospheric Environment Assessment of Effects TSD, Appendix C	To define the input parameters for the EA assessment Input to atmospheric dispersion modelling

* - For 3 units for EPR, or 4 units for BWRX-300, AP1000, ACR-1000, or EC6

Report

OPG Proprietary		
Document Number: N-REP-01200-10000	Usage Classification: N/A	
Sheet Number: N/A	Revision Number: R006	Page: Page 90 of 147

Title: Use of Plant Parameters Envelope to Encompass the Reactor Designs being considered for the Darlington Site

PPE Parameter			Prorated	PPE Single Unit Value PPE Pro-rated Value*	Limiting Reactor	Where Used	How Used
ID No.	Name	Definition					
16.1.2	Diesel Exhaust Elevation	The elevation above finished grade of the release point for standby diesel exhaust releases	N	3 m	EC6, ACR-1000	Scope of Project for EA Purposes TSD: Section 4.5.3.3, Table 4.5-6 Atmospheric Environment Assessment of Effects TSD, Appendix C	To define the input parameters for the EA assessment Input to atmospheric dispersion modelling
16.1.3	Diesel Flue Gas Effluents	The expected combustion products and anticipated quantities released to the environment due to operation of the emergency standby diesel generators	Y	Refer to Table 4.10	EC6, AP1000	Atmospheric Environment Assessment of Environmental Effects TSD: Table 4.3-5	This PPE value was considered but not used in the assessment
				Refer to Table 4.11	AP1000, EC6, EPR		
16.1.4	Diesel Noise	The maximum expected sound level produced by operation of diesel engines turbines, measured at 50 feet from the noise source	N	98-104 dBa@7m	EC6, ACR-1000	Scope of Project for EA Purposes TSD: Table 4.5-6 (page4-47)	This PPE value was considered but not used in the assessment
16.1.5	Diesel Fuel Type	The type of fuel oil required for proper operation of the diesel engines	N	No. 2 Fuel Oil	EPR, AP1000, EC6, ACR-1000	Scope of Project for EA Purposes TSD: Section 4.5.3.3, Table 4.5-6 Atmospheric Environment Assessment of Effects TSD, Appendix C	To define the input parameters for the EA assessment Input to atmospheric dispersion modelling
17 Plant Characteristics							
17.1 Access Routes							
17.1.1	Heavy Haul Routes	The land usage required for permanent heavy haul routes to support normal operations and refuelling	N	3.64 ha	EPR	Not used in Environmental Impact Statement or Site Evaluation Studies	N/A
			Y	4.00 ha	ACR-1000		
17.1.2	Spent Fuel Cask Weight	The weight of the heaviest expected shipment during normal plant operations and refuelling	N	113 tonnes	BWRX-300	Not used in Environmental Impact Statement or Site Evaluation Studies	N/A
17.2 Acreage							
17.2.1	Office Facilities	The land area required to provide space for plant facilities	Y	10.92 ha 10.92 ha	AP1000 AP1000	Site Evaluation Report – Evaluation of Geotechnical Aspects:	Considered for the evaluation of the foundation and the bearing capacity.

* - For 3 units for EPR, or 4 units for BWRX-300, AP1000, ACR-1000, or EC6

Report

OPG Proprietary		
Document Number: N-REP-01200-10000	Usage Classification: N/A	
Sheet Number: N/A	Revision Number: R006	Page: Page 91 of 147

Title: Use of Plant Parameters Envelope to Encompass the Reactor Designs being considered for the Darlington Site

PPE Parameter			Prorated	PPE Single Unit Value PPE Pro-rated Value*	Limiting Reactor	Where Used	How Used
ID No.	Name	Definition					
17.2.2	Parking Lots		Y	2.5 ha 2.5 ha	EPR EPR	Page 55 (Table 5.1-2) Pages 60-61 (Section 5.3) Pages 61-62 (Section 5.4) Pages 62-64 (Section 5.5)	
17.2.3	Permanent Support Facilities		Y	6.5 ha 10.8 ha	EPR ACR-1000		
17.2.4	Power Block		Y	6.88 ha 20.6 ha	EPR EPR		
17.2.5	Protected Area		Y	19.02 ha 38.69 ha	EPR ACR-1000		
17.3 Plant Population							
17.3.1	Operation	The number of people required to operate and maintain the plant	Y	1,040 people 2,080 people	ACR-1000 ACR-1000	Not used in Environmental Impact Statement or Site Evaluation Studies	N/A
17.3.2	Refuelling/ Major Maintenance	The additional number of temporary staff required to conduct refuelling and major maintenance activities	N	1,000 people	AP1000, ACR-1000	Not used in Environmental Impact Statement or Site Evaluation Studies	N/A
18 Construction							
18.1 Access Routes							
18.1.1	Construction Module Dimensions	The maximum expected length, width, and height of the largest construction modules or components and delivery vehicles to be transported to the site during construction	N	Largest module: Main Condenser, shipped in 9 modules. Upper Module dimensions w/o shipping protection: 10.45m H X 17.37m L X 10.1m W Longest Item: Turbine Hall Trusses and Crane Beams, approx 47 m L	ACR-1000 EC6	Scope of Project TSD: Section 3.3.2.5	Data provided for information purposes.
18.1.2	Heaviest Construction Shipment	The maximum expected weight of the heaviest construction shipment to the site	N	Heaviest single piece of equipment shipped by land: 422 metric tons (includes packaging)	ACR-1000	Scope of Project TSD: Section 3.3.2.5	Data provided for information purposes.

* - For 3 units for EPR, or 4 units for BWRX-300, AP1000, ACR-1000, or EC6

Report

OPG Proprietary		
Document Number: N-REP-01200-10000	Usage Classification: N/A	
Sheet Number: N/A	Revision Number: R006	Page: Page 92 of 147

Title: Use of Plant Parameters Envelope to Encompass the Reactor Designs being considered for the Darlington Site

PPE Parameter			Prorated	PPE Single Unit Value PPE Pro-rated Value*	Limiting Reactor	Where Used	How Used
ID No.	Name	Definition					
				Heaviest consolidated piece of equipment shipped by water: 1,600 metric tons total (excludes packaging) (9 modules, tube bundles installed). Calandria: 800 tons			
18.2 Acreage							
18.2.1	Laydown Area	The land area required to provide space for construction support facilities	Y	14.33 ha 23.46 ha	EC6 ACR-1000	Not used in Environmental Impact Statement or Site Evaluation Studies	N/A
18.2.2	Temporary Construction Facilities		Y	21 ha 21 ha	EPR EPR	Not used in Environmental Impact Statement or Site Evaluation Studies	N/A
18.3	Construction Noise	The maximum expected sound level due to construction activities, measured at 50 feet from the noise source	N	76-101 dBa@15m	EC6, ACR-1000, AP1000	Not used in Environmental Impact Statement or Site Evaluation Studies	N/A
18.4	Plant Construction Population	Peak employment during plant construction	Y	4,200 people 5,500 people	EPR ACR-1000	Scope of Project for EA Purposes TSD: 3.3.4 Human Health TSD: Section 5.3 Social Economic TSD: Section 3.3.1 Traffic and Transportation Effects TSD: Section 3.3.1	This PPE value was considered but not used in the assessment
18.5	Site Preparation Duration	Length of time required to prepare the site for construction	N	18 months	EC6, AP1000	Not used in Environmental Impact Statement or Site Evaluation Studies	N/A
19.1.1	Decommissioning Dimensions	The maximum expected length, width, and height of the largest components and delivery vehicles to be transported on or off site during decommissioning	N	Largest module: Main Condenser, shipped in 9 modules. Upper Module dimensions w/o shipping protection: 10.45m H X 17.37m L X 10.1m W	ACR-1000	Not used in Environmental Impact Statement or Site Evaluation Studies	N/A
				Longest Item: Turbine Hall Trusses and Crane Beams, approx 47 m L	EC6		
19.1.2	Heaviest Decommissioning	The maximum expected weight of the heaviest shipment on or	N	The heaviest piece of equipment is the Main	EC6, ACR-1000	Not used in Environmental Impact Statement or Site Evaluation Studies	N/A

* - For 3 units for EPR, or 4 units for BWRX-300, AP1000, ACR-1000, or EC6

Report

OPG Proprietary		
Document Number: N-REP-01200-10000	Usage Classification: N/A	
Sheet Number: N/A	Revision Number: R006	Page: Page 93 of 147
Title: Use of Plant Parameters Envelope to Encompass the Reactor Designs being considered for the Darlington Site		

PPE Parameter			Prorated	PPE Single Unit Value PPE Pro-rated Value*	Limiting Reactor	Where Used	How Used
ID No.	Name	Definition					
	Dimensions	off the site during decommissioning		Condenser with a weight of 1600 metric tons.			
19.2 Acreage							
19.2.1	Laydown Area	The land area required to provide space for decommissioning support facilities	N	14.3 ha	ACR-1000	Not used in Environmental Impact Statement or Site Evaluation Studies	N/A
			Y	19.6 ha	EC6, ACR-1000		
19.2.2	Temporary Decommissioning Facilities	space for decommissioning support facilities	N	2.2 ha	EC6, ACR-1000	Not used in Environmental Impact Statement or Site Evaluation Studies	N/A
			Y	2.7 ha			
19.3 Decommissioning Noise							
19.3	Decommissioning Noise	The maximum expected sound level due to decommissioning activities, measured at 50 feet from the noise source	N	80-90 dBa@15.2 m	EPR	Not used in Environmental Impact Statement or Site Evaluation Studies	N/A
19.4 Plant Decommissioning							
19.4	Plant Decommissioning Population	Peak employment during plant decommissioning	Y	300 people	EC6, ACR-1000	Not used in Environmental Impact Statement or Site Evaluation Studies	N/A
				600 people	EPR, ACR-1000		
19.5 Site Preparation Duration							
19.5	Site Preparation Duration	Length of time required to prepare the site for decommissioning	N	1-5 years	EPR, EC6 AP1000, ACR-1000	Not used in Environmental Impact Statement or Site Evaluation Studies	N/A
19.6 Delay Time Prior to Decommissioning							
19.6	Delay time prior to decommissioning	Length of time required to allow radiation fields to decrease prior to commencing decommissioning	N	32 years	EC6, ACR-1000	Not used in Environmental Impact Statement or Site Evaluation Studies	N/A
19.7 Mass of Plant Material and Components							

* - For 3 units for EPR, or 4 units for BWRX-300, AP1000, ACR-1000, or EC6

Report

OPG Proprietary		
Document Number: N-REP-01200-10000	Usage Classification: N/A	
Sheet Number: N/A	Revision Number: R006	Page: Page 94 of 147
Title: Use of Plant Parameters Envelope to Encompass the Reactor Designs being considered for the Darlington Site		

PPE Parameter			Prorated	PPE Single Unit Value PPE Pro-rated Value*	Limiting Reactor	Where Used	How Used
ID No.	Name	Definition					
19.7.1	Mass of Highly Active Material	Total mass of plant components and materials that are highly active and require specially shielded handling techniques during, and/or significant time delays prior to, decommissioning	Y	6,462 Mg 25,848 Mg	EC6 EC6	Not used in Environmental Impact Statement or Site Evaluation Studies	N/A
19.7.2	Mass of Moderately Active Material	Total mass of plant components and materials that are moderately active and require some shielded handling techniques during, and/or some time delays prior to, decommissioning	Y	4,893 Mg 13,980 Mg	EC6 EC6	Not used in Environmental Impact Statement or Site Evaluation Studies	N/A
19.7.3	Mass of Low-Activity Material	Total mass of plant components and materials that are slightly active but require no shielded handling techniques during, and/or no time delays prior to, decommissioning	Y	17,095 Mg 52,600 Mg	ACR-1000 ACR-1000	Not used in Environmental Impact Statement or Site Evaluation Studies	N/A
19.7.4	Mass of Non-Active Material	Total mass of plant components and materials that are not active but must be transported and/or handled during decommissioning	Y	180,000Mg 540,000Mg	EPR EPR	Not used in Environmental Impact Statement or Site Evaluation Studies	N/A
19.8 Decommissioning Materials							
19.8.1	Concrete	Total mass of concrete to be used in decommissioning	Y	Not available at this time	EPR	Not used in Environmental Impact Statement or Site Evaluation Studies	N/A
19.8.2	Landfill	Total mass of landfill to be used in decommissioning	Y	640,000 Mg 2,560,000 Mg	EC6, ACR-1000 ACR-1000	Not used in Environmental Impact Statement or Site Evaluation Studies	N/A

* - For 3 units for EPR, or 4 units for BWRX-300, AP1000, ACR-1000, or EC6

Report

OPG Proprietary		
Document Number: N-REP-01200-10000	Usage Classification: N/A	
Sheet Number: N/A	Revision Number: R006	Page: 95 of 147

Title:
Use of Plant Parameters Envelope to Encompass the Reactor Designs being considered for the Darlington Site

B.1.5 Table 4. 1: Airborne Source Term, Single Reactor (Parameter 9.5.1)

Table 4.1: Airborne Source Term, Single Reactor					
	Airborne Source Term (Bq/y)				
Isotope	EPR	AP1000	ACR-1000	EC6	BWRX-300
Kr-83m					3.3E+11
Kr-85m	5.55E+12	1.33E+12			3.4E+10
Kr-85	1.26E+15	1.52E+14			2.2E+12
Kr-87	1.96E+12	5.55E+11			1.2E+11
Kr-88	6.66E+12	1.70E+12			1.2E+11
Kr-89					1.2E+13
Kr-90					
Xe-131m	1.30E+14	6.66E+13			3.8E+10
Xe-133m	6.66E+12	3.22E+12			1.1E+09
Xe-133	3.18E+14	1.70E+14			1.6E+12
Xe-135m	5.18E+11	2.59E+11			1.2E+12
Xe-135	4.44E+13	1.22E+13			1.3E+12
Xe-137	0.00E+00				1.7E+12
Xe-138	4.44E+11	2.22E+11			2.4E+12
Xe-139					
I-131	3.26E+08	4.44E+09	1.60E+07	1.6E+07	5.2E+08
I-132					3.1E+09
I-133	1.18E+09	1.48E+10			2.4E+09
I-134					8.7E+09
I-135					4.6E+09
C-14	2.70E+11	2.70E+11	2.76E+11	3.2E+11	4.0E+11
Na-24					1.4E+06
P-32					6.9E+05
Ar-41	1.26E+12	1.26E+12			3.2E+08
Cr-51	3.59E+06	2.26E+07			2.0E+07
Mn-54	2.11E+06	1.59E+07			1.2E+07
Mn-56					4.5E+05

Report

OPG Proprietary		
Document Number: N-REP-01200-10000	Usage Classification: N/A	
Sheet Number: N/A	Revision Number: R006	Page: 96 of 147

Title:
Use of Plant Parameters Envelope to Encompass the Reactor Designs being considered for the Darlington Site

Table 4.1: Airborne Source Term, Single Reactor					
Isotope	Airborne Source Term (Bq/y)				
	EPR	AP1000	ACR-1000	EC6	BWRX-300
Fe-55					2.4E+07
Co-57	3.03E+05	3.03E+05			
Co-58	1.78E+07	8.51E+08			5.2E+06
Co-60	4.07E+06	3.22E+08			1.1E+07
Fe-59	1.04E+06	2.92E+06			5.8E+06
Ni-63					2.5E+04
Cu-64					5.8E+06
Zn-65					4.9E+06
Rb-89					4.4E+04
Sr-89	5.92E+06	1.11E+08			8.0E+04
Sr-90	2.33E+06	4.44E+07			3.6E+03
Y-90					8.8E+02
Sr-91					1.7E+06
Sr-92					1.0E+06
Y-91					8.9E+05
Y-92					4.1E+05
Y-93					1.3E+05
Zr-95	3.70E+05	3.70E+07			1.9E+06
Nb-95	1.55E+06	9.25E+07			1.8E+06
Mo-99					2.6E+06
Tc-99m					2.2E+05
Ru-103	6.29E+05	2.96E+06			4.5E+05
Rh-103m					1.9E+03
Ru-106	2.89E+04	2.89E+06			7.3E+04
Rh-106					1.0E+04
Ag-110m					2.4E+04
Sb-124					4.9E+02
Sb-125	2.26E+04	2.26E+06			

Report

OPG Proprietary		
Document Number: N-REP-01200-10000		Usage Classification: N/A
Sheet Number: N/A	Revision Number: R006	Page: 97 of 147

Title:
Use of Plant Parameters Envelope to Encompass the Reactor Designs being considered for the Darlington Site

Table 4.1: Airborne Source Term, Single Reactor					
	Airborne Source Term (Bq/y)				
Isotope	EPR	AP1000	ACR-1000	EC6	BWRX-300
Te-129m					8.4E+05
Te-131m					1.5E+05
Te-132					6.8E+04
Cs-134	1.78E+06	8.51E+07			6.6E+05
Cs-136	1.22E+06	3.15E+06			3.7E+05
Cs-137	3.33E+06	1.33E+08			1.0E+06
Cs-138					1.1E+05
Ba-140	1.55E+05	1.55E+07			7.1E+06
La-140					1.6E+06
Ce-141	4.81E+05	1.55E+06			4.5E+05
Ce-144					7.2E+04
Pr-144					8.4E+01
W-187					5.3E+05
Np-239					1.8E+06
Particulates			4.74E+07	4.75E+07	
Total (without H-3)	1.77E+15	4.10E+14	5.93E+13	3.73E+13	2.2E+13
H-3	6.67E+12	1.30E+13	5.00E+13	2.45E+14	9.7E+11
Total Noble Gases	1.77E+15	4.08E+14	5.90E+13	3.7E+13	2.3E+13

Report

OPG Proprietary		
Document Number: N-REP-01200-10000		Usage Classification: N/A
Sheet Number: N/A	Revision Number: R006	Page: 98 of 147

Title:
Use of Plant Parameters Envelope to Encompass the Reactor Designs being considered for the Darlington Site

B.1.6 Table 4. 2: Airborne Source Term, Prorated (Parameter 9.5.1)

Table 4.2: Airborne Source Term Prorated					
	Airborne Source Term (Bq/y)				
Isotope	EPR	AP1000	ACR-1000	EC6	BWRX-300
Kr-83m					1.3E+12
Kr-85m	1.67E+13	5.33E+12			1.4E+11
Kr-85	3.77E+15	6.07E+14			8.8E+12
Kr-87	5.88E+12	2.22E+12			4.8E+11
Kr-88	2.00E+13	6.81E+12			4.8E+11
Kr-89					4.8E+13
Kr-90					
Xe-131m	3.89E+14	2.66E+14			1.5E+11
Xe-133m	2.00E+13	1.29E+13			4.4E+09
Xe-133	9.55E+14	6.81E+14			6.4E+12
Xe-135m	1.55E+12	1.04E+12			4.8E+12
Xe-135	1.33E+14	4.88E+13			5.2E+12
Xe-137					6.8E+12
Xe-138	1.33E+12	8.88E+11			9.6E+12
Xe-139					
I-131	9.77E+08	1.78E+10	6.40E+07	6.4E+07	2.1E+09
I-132					1.2E+10
I-133	3.55E+09	5.92E+10			9.6E+09
I-134					3.5E+10
I-135					1.8E+10
C-14	8.10E+11	1.08E+12	1.10E+12	1.28E+12	1.6E+12
Na-24					5.6E+06
P-32					2.8E+06
Ar-41	3.77E+12	5.03E+12			1.3E+09
Cr-51	1.08E+07	9.03E+07			8.0E+07
Mn-54	6.33E+06	6.36E+07			4.8E+07
Mn-56					1.8E+06

Report

OPG Proprietary		
Document Number: N-REP-01200-10000		Usage Classification: N/A
Sheet Number: N/A	Revision Number: R006	Page: 99 of 147

Title:
Use of Plant Parameters Envelope to Encompass the Reactor Designs being considered for the Darlington Site

Table 4.2: Airborne Source Term Prorated					
	Airborne Source Term (Bq/y)				
Isotope	EPR	AP1000	ACR-1000	EC6	BWRX-300
Fe-55					9.6E+07
Co-57	9.10E+05	1.21E+06			
Co-58	5.33E+07	3.40E+09			2.1E+07
Co-60	1.22E+07	1.29E+09			4.4E+07
Fe-59	3.11E+06	1.17E+07			2.3E+07
Ni-63					1.0E+05
Cu-64					2.3E+07
Zn-65					2.0E+07
Rb-89					1.8E+05
Sr-89	1.78E+07	4.44E+08			3.2E+05
Sr-90	6.99E+06	1.78E+08			1.4E+04
Y-90					3.5E+03
Sr-91					6.8E+06
Sr-92					4.0E+06
Y-91					3.6E+06
Y-92					1.6E+06
Y-93					5.2E+05
Zr-95	1.11E+06	1.48E+08			7.6E+06
Nb-95	4.66E+06	3.70E+08			7.2E+06
Mo-99					1.0E+07
Tc-99m					8.8E+05
Ru-103	1.89E+06	1.18E+07			1.8E+06
Rh-103m					7.6E+03
Ru-106	8.66E+04	1.15E+07			2.9E+05
Rh-106					4.0E+04
Ag-110m					9.6E+04
Sb-124					2.0E+03
Sb-125	6.77E+04	9.03E+06			
Te-129m					3.4E+06
Te-131m					6.0E+05
Te-132					2.7E+05

Report

OPG Proprietary		
Document Number: N-REP-01200-10000		Usage Classification: N/A
Sheet Number: N/A	Revision Number: R006	Page: 100 of 147

Title:
Use of Plant Parameters Envelope to Encompass the Reactor Designs being considered for the Darlington Site

Table 4.2: Airborne Source Term Prorated					
	Airborne Source Term (Bq/y)				
Isotope	EPR	AP1000	ACR-1000	EC6	BWRX-300
Cs-134	5.33E+06	3.40E+08			2.6E+06
Cs-136	3.66E+06	1.26E+07			1.5E+06
Cs-137	9.99E+06	5.33E+08			4.0E+06
Cs-138					4.4E+05
Ba-140	4.66E+05	6.22E+07			2.8E+07
La-140					6.4E+06
Ce-141	1.44E+06	6.22E+06			1.8E+06
Ce-144					2.9E+05
Pr-144					3.4E+02
W-187					2.1E+06
Np-239					7.2E+06
Particulates			1.89E+08	1.9E+08	
Total (without H-3)	5.31E+15	1.64E+15	2.37E+14	1.49E+14	9.0E+13
H-3	2.00E+13	5.18E+13	2.00E+14	9.80E+14	3.9E+12
Total Noble Gases	5.31E+15	1.63E+15	2.36E+14	1.48E+14	9.2E+13

Report

OPG Proprietary		
Document Number: N-REP-01200-10000		Usage Classification: N/A
Sheet Number: N/A	Revision Number: R006	Page: 101 of 147

Title:
Use of Plant Parameters Envelope to Encompass the Reactor Designs being considered for the Darlington Site

B.1.7 Table 4. 3: Liquid Effluent Source Term, Single Reactor (Parameter 10.3.1)

Table 4.3: Liquid Effluent Source Term, Single Reactor					
	Liquid Effluent Source Term (Bq/y)				
Isotope	EPR	AP1000	ACR 1000	EC6	BWRX-300 ¹
C-14			2.10E+10	2.1E+10	
Na-24	2.27E+08	6.03E+07			
P-32					
Cr-51	3.81E+07	6.85E+07			
Mn-54	2.00E+07	4.81E+07			
Mn-56					
Fe-55	1.52E+07	3.70E+07			
Fe-59	3.70E+06	7.40E+06			
Co-56					
Co-57					
Co-58	5.74E+07	1.24E+08			
Co-60	6.66E+06	1.63E+07			
Ni-63					
Cu-64					
Zn-65	6.29E+06	1.52E+07			
Br-84	0.00E+00	7.40E+05			
Rb-88	0.00E+00	9.99E+06			
Rb-89					
Sr-89	1.85E+06	3.70E+06			
Sr-90	0.00E+00	3.70E+05			
Sr-91	2.96E+06	7.40E+05			
Y-90					
Y-91					
Y-91m	0.00E+00	3.70E+05			
Sr-92					

¹ For normal operations, the BWRX-300 maintains a zero liquid effluent release strategy and therefor does not contain a source term for this parameter.

Report

OPG Proprietary		
Document Number: N-REP-01200-10000		Usage Classification: N/A
Sheet Number: N/A	Revision Number: R006	Page: 102 of 147

Title:
Use of Plant Parameters Envelope to Encompass the Reactor Designs being considered for the Darlington Site

Table 4.3: Liquid Effluent Source Term, Single Reactor					
	Liquid Effluent Source Term (Bq/y)				
Isotope	EPR	AP1000	ACR 1000	EC6	BWRX-300 ¹
Y-92					
Y-93	1.33E+07	3.33E+06			
Zr-95	4.81E+06	8.51E+06			
Nb-95	3.70E+06	7.77E+06			
Mo-99	6.48E+07	2.11E+07			
Tc-99m	6.29E+07	2.04E+07			
Ru-103	9.29E+07	1.82E+08			
Rh-103m	9.29E+07	1.82E+08			
Ru-106	1.13E+09	2.72E+09			
Rh-106	1.13E+09	2.72E+09			
Ag-110m	1.63E+07	3.89E+07			
Ag-110	2.22E+06	5.18E+06			
Sb-124					
Te-129m	2.22E+06	4.44E+06			
Te-129	1.48E+06	5.55E+06			
Te-131m	1.15E+07	3.33E+06			
Te-131	2.22E+06	1.11E+06			
Te-132	1.78E+07	8.88E+06			
I-131	1.27E+09	5.23E+08			
I-132	4.26E+07	6.07E+07			
Te-132					
I-133	1.29E+09	2.48E+08			
I-134	0.00E+00	3.00E+07			
I-135	5.55E+08	1.84E+08			
Cs-134	9.81E+07	3.67E+08			
Cs-136	1.15E+07	2.33E+07			
Cs-137	1.30E+08	4.93E+08			
Ba-137m	1.21E+08	4.61E+08			

Report

OPG Proprietary		
Document Number: N-REP-01200-10000		Usage Classification: N/A
Sheet Number: N/A	Revision Number: R006	Page: 103 of 147

Title:
Use of Plant Parameters Envelope to Encompass the Reactor Designs being considered for the Darlington Site

Table 4.3: Liquid Effluent Source Term, Single Reactor					
	Liquid Effluent Source Term (Bq/y)				
Isotope	EPR	AP1000	ACR 1000	EC6	BWRX-300 ¹
Cs-138					
Ba-140	1.56E+08	2.04E+08			
La-140	2.82E+08	2.75E+08			
Ce-141	1.85E+06	3.33E+06			
Ce-143	2.26E+07	7.03E+06			
Pr-143	1.85E+06	4.81E+06			
Ce-144	4.88E+07	1.17E+08			
Pr-144	4.88E+07	1.17E+08			
W-187	1.70E+07	4.81E+06			
Np-239	2.15E+07	8.88E+06			
Ba-139					
Br-83					
La-142					
Ru-105					
Zn-69m					
All others	7.40E+05	7.40E+05			
H-3	6.14E+13	3.74E+13	1.20E+14	4.0E+14	

Report

OPG Proprietary		
Document Number: N-REP-01200-10000		Usage Classification: N/A
Sheet Number: N/A	Revision Number: R006	Page: 104 of 147

Title:
Use of Plant Parameters Envelope to Encompass the Reactor Designs being considered for the Darlington Site

B.1.8 Table 4. 4: Liquid Effluent Source Term, Prorated (Parameter 10.3.1)

Table 4.4: Liquid Effluent Source Term Prorated					
	Liquid Effluent Source Term (Bq/y)				
Isotope	EPR	AP1000	ACR 1000	EC6	BWRX-300 ²
C-14			8.40E+10	8.4E+10	
Na-24	6.80E+08	2.41E+08			
P-32	0.00E+00	0.00E+00			
Cr-51	1.14E+08	2.74E+08			
Mn-54	5.99E+07	1.92E+08			
Mn-56					
Fe-55	4.55E+07	1.48E+08			
Fe-59	1.11E+07	2.96E+07			
Co-56					
Co-57					
Co-58	1.72E+08	4.97E+08			
Co-60	2.00E+07	6.51E+07			
Ni-63					
Cu-64					
Zn-65	1.89E+07	6.07E+07			
Br-84		2.96E+06			
Rb-88		4.00E+07			
Rb-89					
Sr-89	5.55E+06	1.48E+07			
Sr-90		1.48E+06			
Sr-91	8.88E+06	2.96E+06			
Y-90					
Y-91					
Y-91m		1.48E+06			

² For normal operations, the BWRX-300 maintains a zero liquid effluent release strategy and therefor does not contain a source term for this parameter.

Report

OPG Proprietary		
Document Number: N-REP-01200-10000		Usage Classification: N/A
Sheet Number: N/A	Revision Number: R006	Page: 105 of 147

Title:
Use of Plant Parameters Envelope to Encompass the Reactor Designs being considered for the Darlington Site

Sr-92					
Y-92					
Y-93	4.00E+07	1.33E+07			
Zr-95	1.44E+07	3.40E+07			
Nb-95	1.11E+07	3.11E+07			
Mo-99	1.94E+08	8.44E+07			
Tc-99m	1.89E+08	8.14E+07			
Ru-103	2.79E+08	7.30E+08			
Rh-103m	2.79E+08	7.30E+08			
Ru-106	3.39E+09	1.09E+10			
Rh-106	3.39E+09	1.09E+10			
Ag-110m	4.88E+07	1.55E+08			
Ag-110	6.66E+06	2.07E+07			
Sb-124					
Te-129m	6.66E+06	1.78E+07			
Te-129	4.44E+06	2.22E+07			
Te-131m	3.44E+07	1.33E+07			
Te-131	6.66E+06	4.44E+06			
Te-132	5.33E+07	3.55E+07			
I-131	3.80E+09	2.09E+09			
I-132	1.28E+08	2.43E+08			
Te-132					
I-133	3.87E+09	9.92E+08			
I-134		1.20E+08			
I-135	1.67E+09	7.36E+08			
Cs-134	2.94E+08	1.47E+09			
Cs-136	3.44E+07	9.32E+07			
Cs-137	3.90E+08	1.97E+09			
Ba-137m	3.64E+08	1.84E+09			

Report

OPG Proprietary		
Document Number: N-REP-01200-10000		Usage Classification: N/A
Sheet Number: N/A	Revision Number: R006	Page: 106 of 147

Title:
Use of Plant Parameters Envelope to Encompass the Reactor Designs being considered for the Darlington Site

Cs-138					
Ba-140	4.67E+08	8.17E+08			
La-140	8.47E+08	1.10E+09			
Ce-141	5.55E+06	1.33E+07			
Ce-143	6.77E+07	2.81E+07			
Pr-143	5.55E+06	1.92E+07			
Ce-144	1.47E+08	4.68E+08			
Pr-144	1.47E+08	4.68E+08			
W-187	5.11E+07	1.92E+07			
Np-239	6.44E+07	3.55E+07			
Ba-139					
Br-83					
La-142					
Ru-105					
Zn-69m					
All others	2.22E+06	2.96E+06			
H-3	1.84E+14	1.49E+14	4.80E+14	1.6E+15	

Report

OPG Proprietary		
Document Number: N-REP-01200-10000	Usage Classification: N/A	
Sheet Number: N/A	Revision Number: R006	Page: 107 of 147

Title:
Use of Plant Parameters Envelope to Encompass the Reactor Designs being considered for the Darlington Site

B.1.9 Table 4. 5: Solid Radwaste Activity Levels, Single Reactor (Parameter 11.2.1)

Table 4.5: Solid Radwaste Activity Levels, Single Reactor				
Isotope	Solid Radwaste Activity Level (Bq/y)			
	ACR-1000	AP-1000	EC6	BWRX-300
Ag-110m	7.50E+10	1.70E+09	9.50E+10	3.27E+09
Am-241				2.02E+09
Am-242m				1.33E+08
Am-243				2.06E+08
Ba-140		3.23E+09		1.08E+11
C-14		1.05E+10		2.40E+11
Ce-141	5.00E+09		5.00E+09	1.30E+10
Ce-144	5.00E+09		5.00E+09	1.03E+10
Cm-242				7.08E+10
Cm-243				2.28E+08
Cm-244				4.38E+10
Cm-245				5.27E+06
Cm-246				1.63E+06
Co-58		2.30E+12		3.24E+11
Co-60	6.10E+11	1.06E+13	7.35E+11	2.21E+12
Cr-51	1.57E+12	1.08E+10	1.95E+12	5.46E+11
Cs-134	5.00E+09		5.00E+09	6.59E+10
Cs-136				3.08E+09
Cs-137	1.30E+11		1.60E+11	1.20E+11
Cu-64				2.56E+10
Fe-55	1.14E+12	1.15E+13	1.42E+12	4.61E+12
Fe-59	2.00E+10		2.50E+10	2.34E+11
Gd-153	1.05E+11		1.30E+11	
H-3		5.94E+10		1.07E+11
I-129				1.03E+03
I-131	2.83E+12		3.51E+12	3.97E+10
I-132				2.66E+07

Report

OPG Proprietary		
Document Number: N-REP-01200-10000		Usage Classification: N/A
Sheet Number: N/A	Revision Number: R006	Page: 108 of 147

Title:
Use of Plant Parameters Envelope to Encompass the Reactor Designs being considered for the Darlington Site

Table 4.5: Solid Radwaste Activity Levels, Single Reactor				
Isotope	Solid Radwaste Activity Level (Bq/y)			
	ACR-1000	AP-1000	EC6	BWRX-300
I-133	1.55E+11		1.90E+11	2.08E+10
I-134				5.52E+02
I-135				4.13E+09
La-140		1.48E+09		1.01E+11
Mn-54	2.00E+10	8.30E+11	2.50E+10	1.73E+12
Mn-56				4.16E+07
Mo-99				1.93E+10
Na-24	1.50E+10		2.00E+10	6.81E+09
Nb-95	5.59E+12	1.20E+10	6.95E+12	1.59E+11
Ni-63		1.17E+13		5.20E+09
Np-237				3.02E+06
Np-239				1.32E+10
P-32				1.11E+10
Pu-238				3.48E+10
Pu-239				1.89E+09
Pu-240				3.41E+09
Pu-241		4.22E+09		6.70E+11
Pu-242				1.33E+07
Rh-103m				1.49E+10
Ru-103	7.50E+10		9.50E+10	1.58E+10
Ru-106	4.50E+10		5.50E+10	1.12E+10
Sb-124	3.90E+11		4.85E+11	
Sr-89				3.05E+09
Sr-90	5.00E+09		5.00E+09	7.65E+08
Sr-91				5.54E+09
Sr-92				1.02E+08
Tc-99m				4.44E+09
Te-129m				2.65E+10
Te-131m				9.95E+08

Report

OPG Proprietary		
Document Number: N-REP-01200-10000		Usage Classification: N/A
Sheet Number: N/A	Revision Number: R006	Page: 109 of 147

Title:
Use of Plant Parameters Envelope to Encompass the Reactor Designs being considered for the Darlington Site

Table 4.5: Solid Radwaste Activity Levels, Single Reactor				
	Solid Radwaste Activity Level (Bq/y)			
Isotope	ACR-1000	AP-1000	EC6	BWRX-300
Te-132				5.53E+08
W-187				3.17E+09
Y-90				6.69E+08
Y-91				6.04E+10
Y-92				5.36E+08
Y-93				4.47E+08
Zn-65				6.80E+11
Zr-95	2.64E+12	2.65E+09	3.28E+12	1.04E+11
Total	1.54E+13	3.70E+13	1.91E+13	1.23E+13

B.1.10 Table 4. 6: Solid Radwaste Activity Levels, Prorated (Parameter 11.2.1)

Table 4.6: Solid Radwaste Activity Levels, Prorated				
	Solid Radwaste Activity Level (Bq/y)			
Isotope	ACR-1000	AP-1000	EC6	BWRX-300
Ag-110m	3.00E+11	6.80E+09	3.80E+11	1.31E+10
Am-241				8.08E+09
Am-242m				5.32E+08
Am-243				8.24E+08
Ba-140		1.29E+10		4.32E+11
C-14		4.20E+10		9.60E+11
Ce-141	2.00E+10		2.00E+10	5.20E+10
Ce-144	2.00E+10		2.00E+10	4.12E+10
Cm-242				2.83E+11
Cm-243				9.12E+08
Cm-244				1.75E+11
Cm-245				2.11E+07
Cm-246				6.52E+06

Report

OPG Proprietary		
Document Number: N-REP-01200-10000		Usage Classification: N/A
Sheet Number: N/A	Revision Number: R006	Page: 110 of 147

Title:
Use of Plant Parameters Envelope to Encompass the Reactor Designs being considered for the Darlington Site

Table 4.6: Solid Radwaste Activity Levels, Prorated				
Isotope	Solid Radwaste Activity Level (Bq/y)			
	ACR-1000	AP-1000	EC6	BWRX-300
Co-58		9.20E+12		1.30E+12
Co-60	2.44E+12	4.24E+13	2.94E+12	8.84E+12
Cr-51	6.28E+12	4.32E+10	7.80E+12	2.18E+12
Cs-134	2.00E+10		2.00E+10	2.64E+11
Cs-136				1.23E+10
Cs-137	5.20E+11		6.40E+11	4.80E+11
Cu-64				1.02E+11
Fe-55	4.56E+12	4.60E+13	5.68E+12	1.84E+13
Fe-59	8.00E+10		1.00E+11	9.36E+11
Gd-153	4.20E+11		5.20E+11	-
H-3		2.38E+11		4.28E+11
I-129				4.12E+03
I-131	1.13E+13	0.00E+00	1.40E+13	1.59E+11
I-132				1.06E+08
I-133	6.20E+11		7.60E+11	8.32E+10
I-134				2.21E+03
I-135				1.65E+10
La-140		5.92E+09		4.04E+11
Mn-54	8.00E+10	3.32E+12	1.00E+11	6.92E+12
Mn-56				1.66E+08
Mo-99				7.72E+10
Na-24	6.00E+10		8.00E+10	2.72E+10
Nb-95	2.24E+13	4.80E+10	2.78E+13	6.36E+11
Ni-63		4.68E+13		2.08E+10
Np-237				1.21E+07
Np-239				5.28E+10
P-32				4.44E+10
Pu-238				1.39E+11

Report

OPG Proprietary		
Document Number: N-REP-01200-10000		Usage Classification: N/A
Sheet Number: N/A	Revision Number: R006	Page: 111 of 147

Title:
Use of Plant Parameters Envelope to Encompass the Reactor Designs being considered for the Darlington Site

Table 4.6: Solid Radwaste Activity Levels, Prorated				
	Solid Radwaste Activity Level (Bq/y)			
Isotope	ACR-1000	AP-1000	EC6	BWRX-300
Pu-239				7.56E+09
Pu-240				1.36E+10
Pu-241		1.69E+10		2.68E+12
Pu-242				5.32E+07
Rh-103m				5.96E+10
Ru-103	3.00E+11		3.80E+11	6.32E+10
Ru-106	1.80E+11		2.20E+11	4.48E+10
Sb-124	1.56E+12		1.94E+12	
Sr-89				1.22E+10
Sr-90	2.00E+10		2.00E+10	3.06E+09
Sr-91				2.22E+10
Sr-92				4.08E+08
Tc-99m				1.78E+10
Te-129m				1.06E+11
Te-131m				3.98E+09
Te-132				2.21E+09
W-187				1.27E+10
Y-90				2.68E+09
Y-91				2.42E+11
Y-92				2.14E+09
Y-93				1.79E+09
Zn-65				2.72E+12
Zr-95	1.06E+13	1.06E+10	1.31E+13	4.16E+11
Total	6.16E+13	1.48E+14	7.64E+13	4.92E+13

Report

OPG Proprietary		
Document Number: N-REP-01200-10000	Usage Classification: N/A	
Sheet Number: N/A	Revision Number: R006	Page: 112 of 147

Title:
Use of Plant Parameters Envelope to Encompass the Reactor Designs being considered for the Darlington Site

B.1.11 Table 4. 7: Blowdown Constituents and Concentrations

Table 4.7: Blowdown Constituents and Concentrations				
Constituent	Concentration (ppm)			Limiting Reactor
	River Source	Well/ Treated Water	Envelope	
Chlorine demand	10.1		10.1	AP1000, ACR-1000, EC6
Free available chlorine	1		1	EPR
Copper		6	6	EPR, AP1000, ACR-1000, EC6
Iron	0.9	4	4	EPR (all 3), EC6 & ACR-1000 (River Source only)
Zinc		1	1	EPR
Phosphate		7.2	7.2	AP1000, ACR-1000, EC6
Sulphate	599	3500	3500	EPR, AP1000, ACR-1000, EC6
Total dissolved solids		17000	17000	EPR, AP1000, ACR-1000, EC6
Total suspended solids	49.5	150	150	EPR, AP1000, ACR-1000, EC6

For Parameters 2.4.3, 2.5.3, 3.3.3

B.1.12 Table 4. 8: Yearly Emissions from Auxiliary Boilers, Single Unit

Table 4.8: Yearly Emissions from Auxiliary Boilers, Single Unit			
Pollutant Discharged	Auxiliary Boiler Emissions (kg)		
	ACR-1000	EC6	AP1000
Particulates	1438	719	7824
Sulphur Oxides	14380	7190	23473
Carbon Monoxide	793	396.5	
Hydrocarbons	40	20	22725
Nitrogen Oxides	8628	4314	

For Parameter 13.2. ACR-1000 values are for single or twin

B.1.13 Table 4. 9: Yearly Emissions from Auxiliary Boilers, Prorated

Table 4.9: Yearly Emissions from Auxiliary Boilers, Prorated			
Pollutant Discharged	Auxiliary Boiler Emissions (kg)		
	ACR-1000	EC6	AP1000

Report

OPG Proprietary		
Document Number: N-REP-01200-10000	Usage Classification: N/A	
Sheet Number: N/A	Revision Number: R006	Page: 113 of 147

Title:

Use of Plant Parameters Envelope to Encompass the Reactor Designs being considered for the Darlington Site

Particulates	2876	2876	31296
Sulphur Oxides	28760	28760	93892
Carbon Monoxide	1586	1586	
Hydrocarbons	80	80	90900
Nitrogen Oxides	17256	17256	

For Parameter 13.2

B.1.14 Table 4. 10: Yearly Emissions From Standby Diesel Generators, Single Unit

Table 4.10: Yearly Emissions from Standby Diesel Generators, Single Unit		
Pollutant Discharged	Quantity (kg)	Limiting Reactor
Particulates	368	AP1000
Sulphur Oxides	1136	AP1000
Carbon Monoxide	1710	EC6
Hydrocarbons	1140	EC6
Nitrogen Oxides	6850	EC6

For Parameter 16.1.3, unit values.

Report

OPG Proprietary		
Document Number: N-REP-01200-10000	Usage Classification: N/A	
Sheet Number: N/A	Revision Number: R006	Page: 114 of 147

Title:
Use of Plant Parameters Envelope to Encompass the Reactor Designs being considered for the Darlington Site

B.1.15 Table 4. 11: Yearly Emissions From Standby Diesel Generators, Prorated

Table 4.11: Yearly Emissions from Standby Diesel Generators, Prorated		
Pollutant Discharged	Quantity (kg)	Limiting Reactor
Particulates	1818	EPR
Sulphur Oxides	4544	AP1000
Carbon Monoxide	6840	EC6
Hydrocarbons	4560	EC6
Nitrogen Oxides	27400	EC6

For Parameter 16.1.3, prorated values.

Report

OPG Proprietary		
Document Number: N-REP-01200-10000		Usage Classification: N/A
Sheet Number: N/A	Revision Number: R006	Page: 115 of 147

Title:

Use of Plant Parameters Envelope to Encompass the Reactor Designs being considered for the Darlington Site

Attachment 1: Background on the Initiation and Application of the PPE Concept in the USA

Use of the composite PPE concept in an environmental assessment framework (i.e., specifically the Early Site Permit (ESP) licensing process) has been accepted in the US. In July 1990 the U.S. Department of Energy (DOE) initiated the Early Site Permit Demonstration Program (ESPDP), through Sandia National Laboratories (SNL). The program objective was to demonstrate the practical implementation of the then new NRC Regulation 10 CFR Part 52 (i.e., the USNRC requirements associated with an applicant obtaining an ESP for a site for a future nuclear plant). One of the products of the ESPDP was the concept of the PPE and the composite PPE. The use of composite PPEs in ESP applications was further discussed and resolved in 2002/2003 by NEI and the USNRC as summarized in the following references:

- (a) letter from R.L. Simard (NEI) to J.B. Lyons (USNRC), "Resolution of Generic Topic ESP-6 (Plant Parameters Envelope Approach for ESP)", December 20, 2002; and
- (b) letter from J.B. Lyons (USNRC) to R.L. Simard (NEI), "Resolution of Early Site Permit Topic 6 (ESP-6) Use of Plant Parameter Envelope (PPE)", February 05, 2003.

In the latter letter the NRC state their acceptance of the use of the PPE concept quite clearly, "The NRC staff agrees with NEI's position that ESP applicants may use the PPE approach as a surrogate for facility information to support required safety and environmental review subject to the observations and clarifications below." Also, as shown on the USNRC website, issue ESP-6, the use of the PPE approach in an ESP framework, is considered resolved based on the previous two references.

The composite PPE approach has been incorporated into three of the four applications to the USNRC for ESPs. The ESP applications that incorporated the composite PPE concept were made by Dominion Nuclear (North Anna site, ESP application made September 25, 2003), System Energy Resources Inc. (Grand Gulf site, ESP application made October 21, 2003) and Exelon Generation Company (Clinton site, ESP application made September 25, 2003). The latest ESP application was made by Southern Nuclear Operating Company (Vogtle site, ESP application made August 15, 2006) and did not use the PPE concept since the utility selected one reactor design (i.e., the AP1000) for the application. The USNRC have issued ESP's for the North Anna, Grand Gulf and Clinton sites on November 20, 2007, April 05, 2007 and March 15, 2007, respectively.

Attachment 2 provides excerpts from the USNRC Safety Evaluation Report (SER) and SER supplement for an ESP at the North Anna site in order to provide specific examples of the use of the composite PPE concept within the ESP licensing process and the response of the USNRC staff to that use. Of particular note is the USNRC's overall conclusion to the SER which states (refer to SER Supplement 1, Section 19), "For the same reasons, the staff also concludes that issuance of the requested ESP will not be inimical to the common defense and security or to the health and safety of the public. If issued, the North Anna ESP may be referenced in an application to construct or to construct and operate a nuclear power reactor, or reactors, with a total generating capacity of up to 9000 megawatts (thermal) at the ESP site, subject to the terms and conditions of the permit." Thus, the effective application of a composite PPE has allowed the USNRC to accept the North Anna site as being suitable for the construction and operation of a nuclear power reactor, or reactors, with a total generating

Report

OPG Proprietary		
Document Number: N-REP-01200-10000		Usage Classification: N/A
Sheet Number: N/A	Revision Number: R006	Page: 116 of 147

<small>Title:</small> Use of Plant Parameters Envelope to Encompass the Reactor Designs being considered for the Darlington Site
--

capacity of up to 9000 megawatts (thermal) even though the actual design of the nuclear plants that would be built had not been determined. Also, the USNRC state their future intentions whereby the actual plant design ultimately submitted for construction at the North Anna site would be reviewed relative to the bounding parameters established by the composite PPE used in the ESP. The USNRC state in Appendix A.4 of Supplement 1 to the SER, "As the PPE is intended to bound multiple reactor designs, the actual design selected in a combined license (COL) or construction permit (CP) application referencing an ESP would be reviewed to ensure that the design fits within the bounding parameter values."

Report

OPG Proprietary		
Document Number: N-REP-01200-10000	Usage Classification: N/A	
Sheet Number: N/A	Revision Number: R006	Page: 117 of 147

Title:

Use of Plant Parameters Envelope to Encompass the Reactor Designs being considered for the Darlington Site

Attachment 2: PPE Related Excerpts from the SERs for the ESP for the North Anna Site

Excerpts from the "Safety Evaluation Report for an Early Site Permit at the North Anna Site", NUREG-1835, September 2005

1.3. Plant Parameter Envelope

The regulations at 10 CFR Part 52, "Early Site Permits; Standard Design Certifications; and Combined Licenses for Nuclear Power Plants," and 10 CFR Part 100, "Reactor Site Criteria," that apply to an ESP do not require an ESP applicant to provide specific design information. However, some design information may be required to address 10CFR 52.17(a)(1), which calls for "an analysis and evaluation of the major structures, systems, and components of the facility that bear significantly on the acceptability of the site under the radiological consequence evaluation factors identified in § 50.34(a)(1) of this chapter." In Section 1.3 of the ESP SSAR, Dominion provided a list of postulated design parameters, referred to as the plant parameter envelope (PPE). The applicant stated that the PPE approach provides sufficient design details to support the NRC's review of the ESP application, while recognizing that new reactor technologies, not envisioned at the time Dominion submitted its ESP application, may become available in the future. Therefore, the applicant stated that it based the PPE on data from selected reactor designs and that the PPE is intended to bound multiple reactor designs. The applicant also stated that the actual reactor design selected would be reviewed at the COL stage to ensure that the design fits within the PPE.

In RAI 1.3-1, the staff asked the applicant to explain its use of the plant parameters in SSAR Table 1.3-1 for the cases in which site-specific characteristics are provided. The staff also requested that the applicant clearly identify site characteristics and plant design parameters that it proposed be included as the bases for an ESP, should one be issued. The applicant responded by providing, in Revision 3 of the ESP application, a new section (i.e., Section 1.9) of its SSAR. In this section, the applicant provided a summary listing of site characteristics that were established by analyses presented throughout the SSAR. The applicant proposed this section as a listing of important site characteristics necessary to establish the findings required by 10 CFR Parts 52 and 100 on the suitability of the proposed ESP site. The applicant stated that this section also provides a listing of design parameters and assumptions about the design of a future nuclear power plant or plants that might be constructed on the ESP site. According to the applicant, the design parameters described in this section are those that are needed to assess the site characteristics.

In RAI 1.3-2, the staff requested that the applicant:

- (a) clarify its use of "bounding values" in Table 1.3-1,
- (b) add the dose criteria in 10 CFR 50.34(a)(1) to the table as "bounding value references" or explain why these references are not needed, and
- (c) clarify the use of "Bound Notes" in the table, including how they were used for the accident analyses.

In its response, the applicant provided clarification and corrections to Table 1.3-1.

Report

OPG Proprietary		
Document Number: N-REP-01200-10000		Usage Classification: N/A
Sheet Number: N/A	Revision Number: R006	Page: 118 of 147

Title:
Use of Plant Parameters Envelope to Encompass the Reactor Designs being considered for the Darlington Site

In RAI 1.3-3, the staff requested that the applicant clarify the relationship between the items in the "bounding values" provided in Table 1.3-1 and the references. The applicant responded that the PPE is a compilation of parameters that generally describe a bounding (or limiting) plant design. According to the applicant, the PPE is not intended to reflect the design of any single reactor type, but to provide assumed parameters for any future reactor(s) that might be built at the ESP site. The applicant stated that it developed assumed parameter values in the PPE from a diverse group of reactor designs, and the "bounding value" is the limiting value from those designs. Finally, the applicant clarified that the "Bound Notes" column in Table 1.3-1 provides information as to the source of the bounding value and other pertinent information for the parameter.

The applicant has provided, through its PPE, sufficient design information to allow it to perform the evaluation required by 10 CFR 52.17(a) (1) to determine the adequacy of the proposed exclusion area and low-population zone (LPZ) for the site. Chapter 15 of the SSAR reports the results of this evaluation. In this evaluation, the applicant used design information limited to the rate of release of radioactivity to the environment as a result of a design-basis accident for hypothetical reactors similar to two representative reactor types from different vendors.

In addition to the information supporting the dose consequence evaluation, the applicant provided other design information in its PPE. Because the applicant is not requesting that an ESP be issued referencing a particular reactor design, the staff's review criterion for the PPE is that the PPE values should not be unreasonable for a reactor that might be constructed on the ESP site. The applicant's PPE is based on various reactor designs that are either certified by the NRC, are in the certification process, or may be submitted for certification in the future. The PPE references the following designs:

- ACR-700 (Atomic Energy of Canada, Ltd.)
- Advanced Boiling-Water Reactor (General Electric)
- AP1000 (Westinghouse Electric Company)
- Economic and Simplified Boiling-Water Reactor (General Electric)
- Gas Turbine Modular Helium Reactor (General Atomics)
- International Reactor Innovative and Secure Project (consortium led by Westinghouse)
- Pebble Bed Modular Reactor (PBMR (Pty) Ltd.).

The staff reviewed the applicant's PPE values and found them to be reasonable. As previously noted, the applicant identified certain PPE values as appropriate for inclusion in an ESP, should one be issued. The staff also reviewed the applicant's proposed list of PPE values and identified certain PPE values as bounding parameters or controlling PPE values as discussed in the individual sections of this SER. A controlling PPE value, or bounding parameter value, is one that necessarily depends on a site characteristic. As the PPE is intended to bound multiple reactor designs, the actual design selected in a COL or construction permit (CP) application referencing any ESP that might be issued in connection with this application would be reviewed to ensure that the design fits within the bounding parameter values. Appendix A to this SER lists the bounding parameters identified for the North Anna ESP site.

Report

OPG Proprietary		
Document Number: N-REP-01200-10000		Usage Classification: N/A
Sheet Number: N/A	Revision Number: R006	Page: 119 of 147

<small>Title:</small> Use of Plant Parameters Envelope to Encompass the Reactor Designs being considered for the Darlington Site
--

Should an ESP be issued for the North Anna ESP site, an entity might wish to reference that ESP, as well as a certified design, in a COL or CP application. Such a COL or CP applicant must demonstrate that the site characteristics established in the ESP bound the postulated site parameters established for the chosen design, and that the design characteristics of the chosen design fall within the bounding parameter values specified in the ESP. Otherwise, the COL or CP applicant must demonstrate that the new design, given the site characteristics in the ESP, complies with the Commission's regulations. Should an entity wish to reference the ESP and a design that is not certified, the COL or CP applicant must demonstrate that the design characteristics of the chosen design, in conjunction with the site characteristics established for the ESP, comply with the Commission's regulations.

Excerpts from the "Safety Evaluation Report for an Early Site Permit at the North Anna Site", September 2006, Supplement 1

11. RADIOLOGICAL EFFLUENT RELEASE DOSE CONSEQUENCES FROM NORMAL OPERATIONS

11.1 Source Terms

The applicant provided information on the radiological impacts on members of the public from gaseous and liquid effluents that would be generated as a normal by-product of nuclear power operations. The applicant described the exposure pathways by which radiation and radioactive effluents can be transmitted to members of the public in the vicinity of the site. The estimates on the maximum doses to the public are based on the available data on the reactor designs being considered using the plant parameter envelope (PPE) approach in which the bounding liquid and gaseous radiological effluents were used in assessing impacts on the public. The applicant evaluated the impact of these doses by comparing them to applicable regulatory limits. Using the PPE approach, Dominion provided a list of fission and activation products that may be released in liquid and gaseous effluents from the postulated two new units. The applicant evaluated the impacts from releases and direct radiation by considering the probable pathways to individuals, populations, and biota near the proposed new units. The applicant also calculated the highest dose from the major exposure pathways for a given receptor.

Based upon these considerations, the staff concludes that radiological doses to members of the public from radioactive gaseous and liquid effluents resulting from the normal operation of one or two new nuclear power plants that might be constructed on the proposed ESP site do not present an undue risk to the health and safety of the public. Therefore, the staff concludes, with respect to radiological effluent releases and dose consequences from normal operations, that appropriate long-term atmospheric dispersion coefficients have been established at the proposed site is acceptable for constructing one or two units falling within the applicant's bounding site-specific PPE, and that the site meets the relevant requirements of 10 CFR

Part 52, "Early Site Permits; Standard Design Certifications; and Combined Licenses for Nuclear Power Plants," and 10 CFR Part 100, "Reactor Site Criteria."

Report

OPG Proprietary		
Document Number: N-REP-01200-10000	Usage Classification: N/A	
Sheet Number: N/A	Revision Number: R006	Page: 120 of 147

Title:

Use of Plant Parameters Envelope to Encompass the Reactor Designs being considered for the Darlington Site

15. ACCIDENT ANALYSIS

15.1 Technical Information in the Application

In Chapter 15, "Accident Analyses," of the site safety analysis report (SSAR), the applicant analyzed the radiological consequences of design-basis accidents (DBAs) to demonstrate that new nuclear units could be located at the proposed early site permit (ESP) site without undue risk to the health and safety of the public, in compliance with the requirements of Title 10, Section 52.17, "Contents of Applications," of the Code of Federal Regulations (10 CFR 52.17) and 10 CFR Part 100, "Reactor Site Criteria." The applicant did not identify a particular reactor design to be considered for the proposed ESP site. Instead, the applicant developed a set of reactor DBA source term parameters using surrogate reactor characteristics. The applicant used these parameters in conjunction with site characteristics for accident analysis purposes to assess the suitability of the proposed ESP site. These plant parameters collectively constitute a plant parameter envelope (PPE). The applicant developed a PPE using seven reactor designs (five water-cooled reactors and two gas-cooled reactors), though it used source terms for only three of these designs as inputs to its DBA analyses. The water-cooled reactors included in the

PPE were (1) a version of the Westinghouse Advanced Plant 1000 (AP1000), (2) the certified

General Electric (GE) Advanced Boiling-Water Reactor (ABWR), (3) the Atomic Energy of Canada Advanced CANDU Reactor (ACR-700), (4) a version of the GE Economic and Simple Boiling-Water Reactor (ESBWR), and (5) the Westinghouse-led International Reactor Innovative and Secure (IRIS) reactor. The ACR-700 is light-water cooled but heavy-water moderated. The two gas-cooled reactors are (1) the General Atomics Gas Turbine Modular Helium Reactor (GT-MHR) and (2) the Pebble Bed Modular Reactor (PBMR). The applicant stated that the PPE values are not intended to be limited to these reactor designs but rather to provide a broad overall outline of a design concept and to include other potential reactor designs if they fall within the parameter values provided in the PPE.

In selecting DBAs for dose consequence analyses, the applicant focused on three light-water reactors (LWRs), the certified ABWR, a version of the AP1000 (Note 4), and a version of the ESBWR (Note 5) to serve as surrogates. The applicant stated that it selected these three reactor designs because they are (or are based on) previously certified standard designs and have recognized bases for postulated accident analyses. Using source terms developed from these three designs, the applicant performed and provided radiological consequence analyses for the following DBAs:

- pressurized-water reactor (PWR) main steamline break
- PWR feedwater system pipe break
- locked rotor accident
- reactor coolant pump shaft break
- PWR rod ejection accident
- BWR control rod drop accident

Report

OPG Proprietary		
Document Number: N-REP-01200-10000	Usage Classification: N/A	
Sheet Number: N/A	Revision Number: R006	Page: 121 of 147

Title:

Use of Plant Parameters Envelope to Encompass the Reactor Designs being considered for the Darlington Site

- failure of small lines carrying primary coolant outside containment
- PWR steam generator tube failure
- BWR main steamline break
- PWR and BWR loss-of-coolant accidents
- fuel-handling accident
- BWR cleanup water line break.

The applicant presented the dose consequence assessment results in SSAR Chapter 15, "Accident Analyses." SSAR Table 15.4-1, "Summary of Design Basis Accident Doses," summarizes the postulated radiological consequences of the DBAs identified above at the proposed exclusion area boundary (EAB) and the low-population zone (LPZ) boundary. The potential doses set forth in the table would be within the radiological dose consequence evaluation factors set forth in 10 CFR 50.34(a)(1). The applicant provided the accident-specific source terms (release rates of radioactive materials from the ESP footprint (PPE values) to the environment) and resulting site-specific dose consequences for each DBA in Tables 15.4-3 through 15.4-31 of the SSAR.

Note 4. As discussed later in this section, the applicant referenced a version of the AP1000 design available at the time it submitted its ESP application. Westinghouse subsequently revised the AP1000 design before the U.S. Nuclear Regulatory Commission (NRC) staff's issuance of a final safety evaluation report (SER) for the AP1000 design certification.

Note 5. The ESBWR considered by the applicant is based on Revision 1 of the ESBWR Design Control Document, Tier 2, submitted by GE in January 2006. The applicant increased the accident source terms by a factor of 1.25 to accommodate uncertainties because the NRC has not yet completed its design certification review.

From a detailed review of this information the USNRC was able to conclude:

Because the applicant has not selected a reactor design to be constructed on the proposed ESP site, the applicant used a PPE approach to demonstrate that it meets these requirements. A PPE is a set of plant design parameters that are expected to bound the characteristics of a reactor(s) that may be constructed at a site, and it serves as a surrogate for actual reactor design information. As discussed in RS-002 and in Chapter 1 of the SER (NUREG-1835), the staff considers the PPE approach to be an acceptable method for assessing site suitability. For the purposes of this analysis, the applicant proposed a fission product release from the PPE (ESP footprint) to the environment, and the staff reviewed the applicant's dose evaluation based on this release.

The staff believes that basing the radiological consequences of the DBAs at the proposed site on the AP1000, ABWR, and ESBWR designs is likely to be valid for the other reactor designs the applicant is considering. Whether the final reactor design selected by the applicant at the North Anna ESP site is in fact bounded by the acceptance made here would be subject to review during the staff's consideration of any COL or CP application. In accordance with 10 CFR 52.79(a)(1), at the COL stage, the staff will evaluate whether the design of the facility falls within the parameters specified in an ESP, if one is issued for the North Anna ESP site. Based on the above evaluation of the applicant's analysis

Report

OPG Proprietary		
Document Number: N-REP-01200-10000		Usage Classification: N/A
Sheet Number: N/A	Revision Number: R006	Page: 122 of 147

Title:

Use of Plant Parameters Envelope to Encompass the Reactor Designs being considered for the Darlington Site

methodology and inputs to that analysis, the staff finds that the applicant's conclusion that the radiological consequences for the chosen surrogate designs comply with the radiological consequence evaluation factors of 10 CFR 50.34(a)(1) is correct.

As described above, the applicant submitted its radiological consequence analyses using the site-specific χ/Q values and PPE source term values and concluded that the proposed site meets the radiological consequence evaluation factors identified in 10 CFR 50.34(a)(1). Based on the reasons given above, the staff finds that the applicant's PPE values for source terms included as inputs to the radiological consequence analyses are reasonable. Further, the staff finds that the applicant's site-specific χ/Q values and dose consequence evaluation

methodology are acceptable. Therefore, the staff concludes that the proposed distances to the EAB and the LPZ outer boundary of the proposed ESP site, in conjunction with the fission product release rates to the environment provided by the applicant as PPE values, are adequate to provide reasonable assurance that the radiological consequences of the DBAs will be within the radiological consequence evaluation factors set forth in 10 CFR 50.34(a)(1) for the proposed ESP site. This conclusion is subject to confirmation at the COL or CP stage that the design of the facility specified by the COL or CP applicant falls within the values of site characteristics and plant parameters specified in any ESP that might issue for the North Anna ESP site. The staff further concludes that (1) the applicant has demonstrated that the proposed

ESP site is suitable for power reactors with source term characteristics bounded by those of the ABWR (at 4386 MWth), AP1000, and ESBWR without undue risk to the health and safety of the public and (2) the applicant has complied with the requirements of 10 CFR 52.17 and 10 CFR Part 100.

19. CONCLUSIONS

In accordance with Subpart A, "Early Site Permits," of Title 10, Part 52, "Early Site Permits, Standard Design Certifications, and Combined Licenses for Nuclear Power Plants," of the Code of Federal Regulations (10 CFR Part 52), the staff of the U.S. Nuclear Regulatory Commission (NRC) reviewed the site safety analysis report and emergency planning information included in the early site permit (ESP) application submitted by Dominion Nuclear North Anna, LLC, for the North Anna ESP site. On the basis of its evaluation and independent analyses as discussed in this supplement and NRC technical report NUREG-1835, "Safety Evaluation Report for an Early Site Permit (ESP) at the North Anna ESP Site," the staff concludes that the North Anna ESP site characteristics comply with the requirements of 10 CFR Part 100, "Reactor Site Criteria," with the limitations and conditions proposed by the staff in this supplement and NRC technical report NUREG-1835 for inclusion in any ESP that might be issued. Further, for the reasons set forth in this supplement and NRC technical report NUREG-1835, the staff concludes that, taking into consideration the site criteria contained in 10 CFR Part 100, a reactor, or reactors, having characteristics that fall within the parameters for the site, and which meets the terms and conditions proposed by the staff in this supplement and NRC technical report NUREG-1835, can be constructed and operated without undue risk to the health and safety of the public. For the same reasons, the staff also concludes that issuance of the requested ESP will not be inimical to the common defense and security or to the health and safety of the public. If

Report

OPG Proprietary		
Document Number: N-REP-01200-10000		Usage Classification: N/A
Sheet Number: N/A	Revision Number: R006	Page: 123 of 147

<small>Title:</small> Use of Plant Parameters Envelope to Encompass the Reactor Designs being considered for the Darlington Site
--

issued, the North Anna ESP may be referenced in an application to construct or to construct and operate a nuclear power reactor, or reactors, with a total generating capacity of up to 9000 megawatts (thermal) at the ESP site, subject to the terms and conditions of the permit.

Report

OPG Proprietary		
Document Number: N-REP-01200-10000		Usage Classification: N/A
Sheet Number: N/A	Revision Number: R006	Page: 124 of 147

Title:

Use of Plant Parameters Envelope to Encompass the Reactor Designs being considered for the Darlington Site

Attachment 3: Description of Reactor Designs Being Considered for the Darlington Site

Areva

Evolutionary Power Reactor (EPR)

Introduction

The EPR is an evolutionary Pressurized Water Reactor (PWR) designed by Framatome ANP, Inc., a jointly-owned subsidiary of AREVA and Siemens. It is a four-loop plant with a rated thermal power of 4,500 MWt (1580 MWe net), a capacity factor of 94% and a design life of 60 years.

The EPR has a basic set of common design features adaptable to the specific regulatory and commercial requirements of each country in which it is offered. The U.S. version of the EPR shares the basic set of design features such as four redundant trains of emergency core cooling, Containment and Shield Buildings, and a core melt retention system for severe accident mitigation. It is adapted to meet applicable U.S. regulatory and commercial requirements.

The concrete Containment Building is enclosed by a Shield Building with an annular space between the two buildings (refer to Figure 1). The pre-stressed concrete shell of the Containment Building is furnished with a steel liner and the Shield Building wall is reinforced concrete. The Containment and Shield Buildings comprise the Reactor Building.

The Reactor Building is surrounded by four Safeguard Buildings and a Fuel Building. The internal structures and components within the Reactor Building, Fuel Building, and two Safeguard Buildings (including the plant Control Room) are protected against aircraft hazard and external explosions. The other two Safeguard Buildings are not protected against aircraft hazard or external explosions; however, they are separated by the Reactor Building, which restricts damage from these external events to a single safety division.

Reactor Coolant System

The EPR is furnished with a four-loop Reactor Coolant System (RCS), composed of a reactor vessel that contains the fuel assemblies, a pressurizer and one Reactor Coolant Pump (RCP) and steam generator per loop.

Reactor Core

The reactor core consists of an array of 241 fuel assemblies. The core is cooled and moderated by light water at a pressure of 2250 psia (15.5 MPa). The coolant contains boron as a neutron absorber.

The core has a fast shutdown system consisting of eighty-nine Rod Cluster Control Assemblies (RCCAs). All RCCAs are of the same type, consisting of twenty-four absorber rods fastened to a common spider assembly.

Report

OPG Proprietary		
Document Number:	N-REP-01200-10000	Usage Classification: N/A
Sheet Number:	Revision Number: R006	Page: 125 of 147

Title:

Use of Plant Parameters Envelope to Encompass the Reactor Designs being considered for the Darlington Site

The reactivity of the core is controlled at power by changing the boron concentration and positioning RCCAs. As a general rule, slow reactivity variations resulting either from changes of the xenon concentration (e.g., following daily load variations) or from the fuel burn-up, or for compensating large reactivity changes associated with large temperature variations during cool down or heat-up phases are compensated by adjusting the boron concentration.

Faster reactivity changes necessary for adjusting the power level are obtained by modifying the RCCA insertion

Fuel design

Each Fuel Bundle is comprised of a 17 x 17 lattice of 265 fuel rods in a square array. Each fuel rod is approximately 4.2 metres long and the fuel enrichment is up to 5 wt% U-235.

Special Safety Systems

The Safety Injection System/ Residual Heat Removal System (SIS/RHRS) performs normal shutdown cooling, as well as emergency coolant injection and recirculation functions to maintain reactor core coolant inventory and provide adequate decay heat removal following a Loss of Coolant Accident (LOCA). The SIS/RHRS also maintains reactor core inventory following a Main Steam Line Break (MSLB).

The SIS/RHRS (refer to Figure 2) consists of four independent trains, each providing injection capability by an accumulator pressurized with nitrogen gas, and a Medium/ Low Head Safety Injection (MHSI/ LHSI) pump. Each of the four SIS trains is provided with a separate suction connection to the In-Containment Refueling Water Storage Tank (IRWST) (described below).

In the injection mode, the MHSI and LHSI/RHR pumps take suction from the IRWST and inject into the RCS through nozzles located in the top of the cold or hot leg piping. These pumps are located in the Safeguard Buildings (refer to Figure 1), close to the containment.

A heat exchanger is located downstream of each LHSI/RHR pump. These heat exchangers are installed in the Safeguard Buildings and cooled by the Component Cooling Water System (CCWS). The accumulators are located inside the containment and inject into the RCS cold legs when the RCS pressure falls below the accumulator pressure, using the same injection nozzles as the LHSI/RHR and MHSI pumps.

The IRWST contains a large amount of borated water used to flood the refueling cavity for normal refueling. It is also the safety-related source of water for emergency core cooling in the event of a LOCA and is a source of water for containment cooling and core melt cooling in the event of a severe accident. During a LOCA, the IRWST collects the discharge from the RCS, allowing it to be recirculated by the SIS.

The IRWST is essentially an open pool (refer to Figure 2) within a partly immersed building structure. The wall of the IRWST has an austenitic stainless steel liner. Each of the four SIS is provided with a separate sump suction connection to the IRWST. Except for the suction isolation valves, all IRWST related components are passive.

Report

OPG Proprietary		
Document Number: N-REP-01200-10000		Usage Classification: N/A
Sheet Number: N/A	Revision Number: R006	Page: 126 of 147

<small>Title:</small> Use of Plant Parameters Envelope to Encompass the Reactor Designs being considered for the Darlington Site
--

The Extra Borating System (EBS) provides high pressure boration to shut down the reactor following accidents. The EBS consists of two identical primary trains, each composed of its own boron tank, a high pressure 100% capacity pump, a test line, and injection lines to the RCS.

The Emergency Feedwater System (EFWS) supplies water to the SGs to maintain water level and remove decay heat following the loss of normal feedwater supplies due to anticipated operational transients and design basis accident conditions. The EFWS has four separate and independent trains, each consisting of a water storage pool, pump, control valves, isolation valves, piping, and instrumentation.

Also inside containment, below the RPV, is a dedicated spreading area for molten core material following a postulated worst-case severe accident.

Report

OPG Proprietary		
Document Number: N-REP-01200-10000	Usage Classification: N/A	
Sheet Number: N/A	Revision Number: R006	Page: 127 of 147

Title:
Use of Plant Parameters Envelope to Encompass the Reactor Designs being considered for the Darlington Site

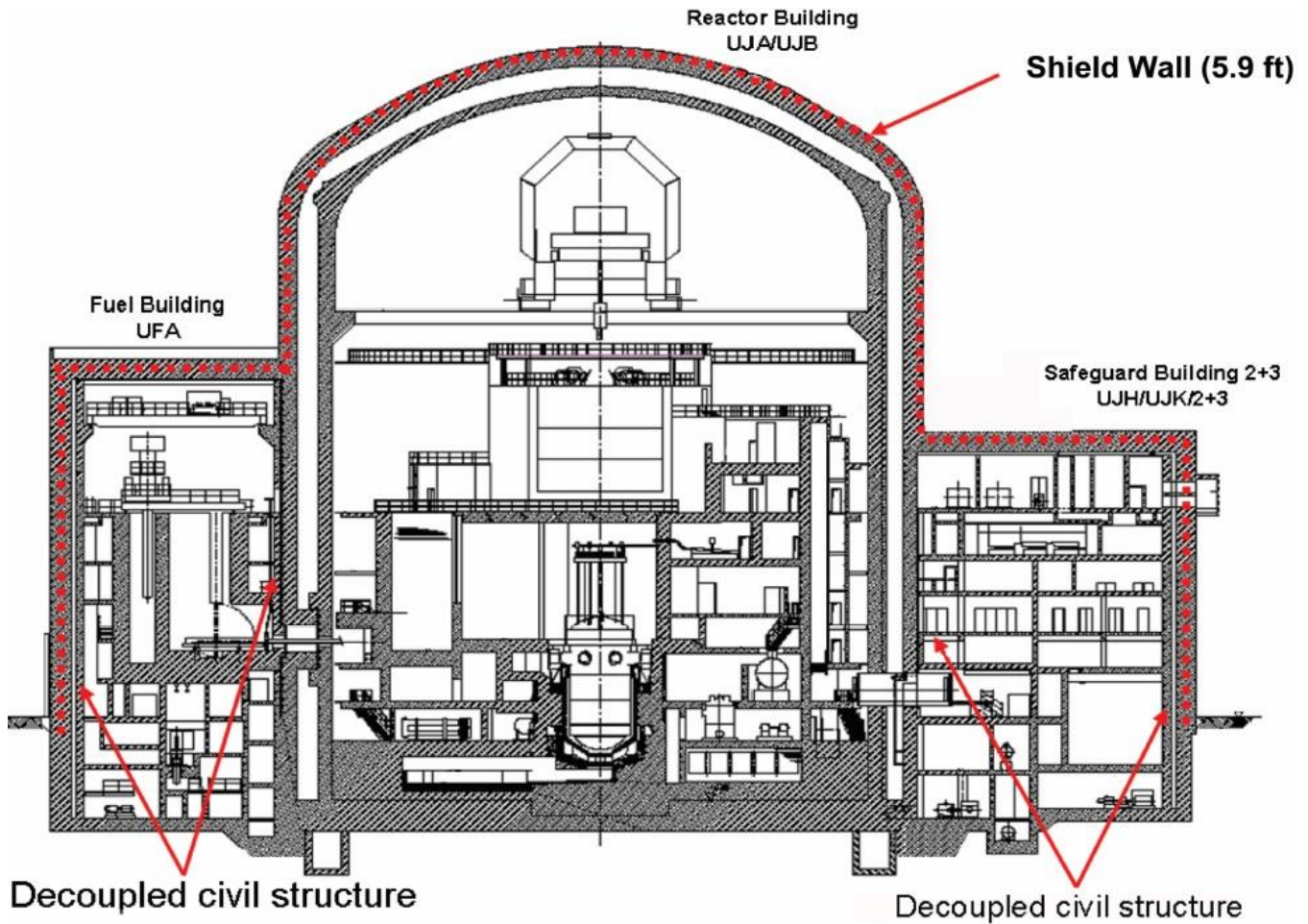

Figure 1

Report

OPG Proprietary		
Document Number: N-REP-01200-10000	Usage Classification: N/A	
Sheet Number: N/A	Revision Number: R006	Page: 128 of 147

Title:

Use of Plant Parameters Envelope to Encompass the Reactor Designs being considered for the Darlington Site

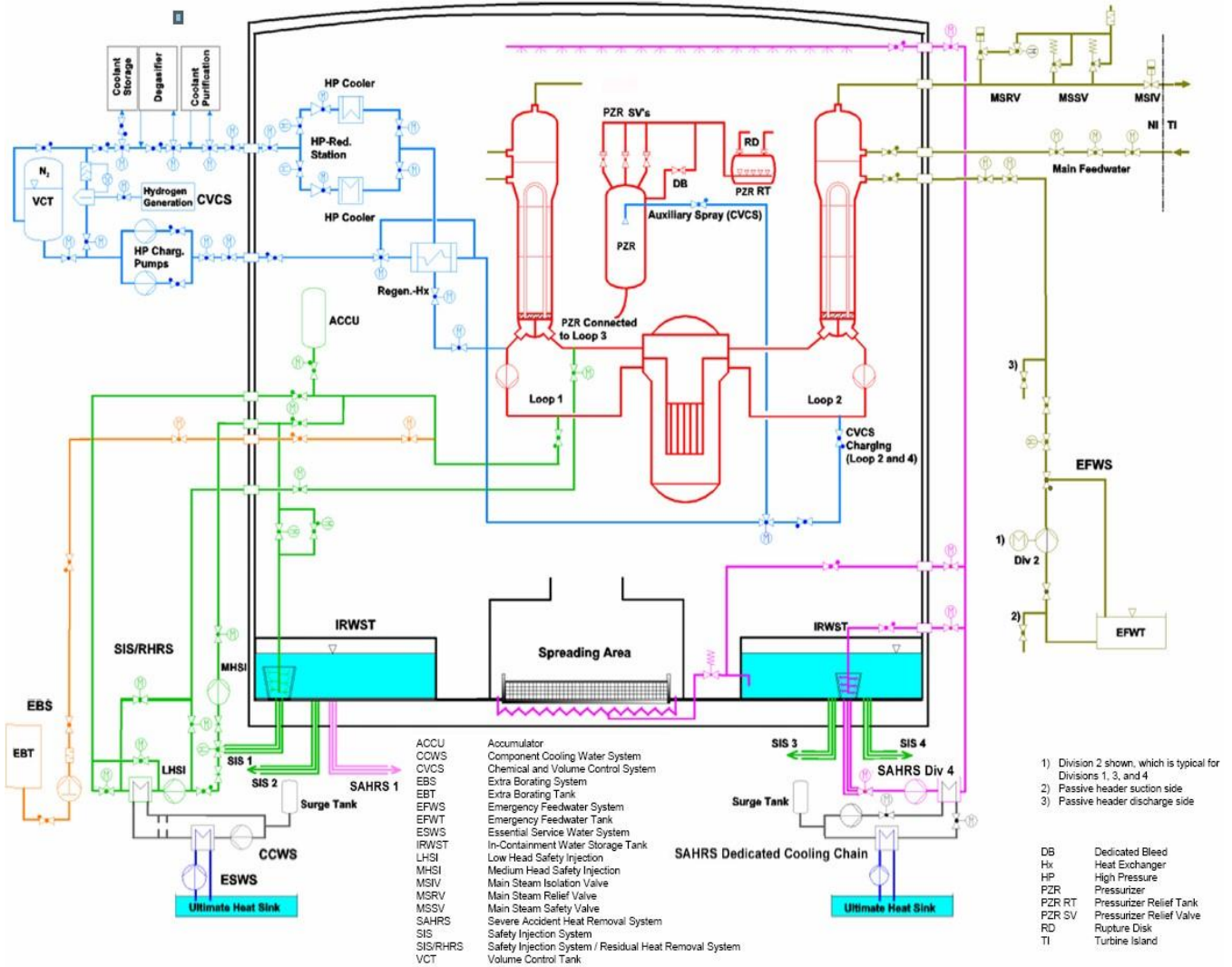

Figure 2

Report

OPG Proprietary		
Document Number: N-REP-01200-10000	Usage Classification: N/A	
Sheet Number: N/A	Revision Number: R006	Page: 129 of 147

Title:

Use of Plant Parameters Envelope to Encompass the Reactor Designs being considered for the Darlington Site

Westinghouse Advanced Passive Reactor (AP1000)

Introduction

The AP1000, certified by the US NRC in 2006, is a scaled up version of the AP600, which was a Westinghouse generation III+ Pressurized Water Reactor (PWR) designed such that its safety systems would operate passively, using only natural forces such as gravity and natural circulation in order to function. The AP1000 produces up to 1117 MWe (net), from 3415 MWth primary power. The AP1000 has a projected capacity factor of 93%.

The overall configuration of the AP1000 consists of a sealed steel containment vessel surrounded by a concrete housing called a containment shield building (refer to Figure 1). The reactor and its associated systems are situated within the containment vessel.

Reactor Coolant System

Like all PWRs, both cooling and moderation are provided by the same working fluid; light water. The coolant is circulated by means of the Reactor Coolant System (RCS) which in turn exchanges heat with a Secondary Cooling System via steam generators.

There are two steam generators, each connected to the reactor pressure vessel by a single hot leg and two cold legs. A pressurizer is connected to one of the hot legs and there are four reactor coolant pumps to provide circulation in the RCS. RCS operating pressure is expected to be 15.5 MPa, with a hot leg temperature of 321°C.

Reactor Core

Mechanical reactivity control is provided by control rods consisting of neutron-absorbing rods fastened at the top end to a common spider assembly. These rods assist in controlling core power distribution, but are also used as the primary shutdown mechanism for normal operation, transients and accidents.

Chemical reactivity control is achieved by changing the concentration of soluble boron in the reactor coolant. Boron concentration is used to compensate for slow reactivity changes during operation, reactivity changes during startup, power changes, and for shutdown. It is adjusted to obtain optimum positioning of the control rods. Also, boron concentration is used to provide shutdown margin for maintenance and refueling operations, or emergencies.

Fuel Design

The fuel assemblies consist of 264 fuel rods in a 17x17 square array. The fuel rods consist of cylindrical, ceramic pellets of slightly enriched uranium dioxide. Fuel assemblies of three different enrichments (2.35, 3.40 & 4.45 wt. % U235) are used in initial core loading. The two lower enrichments are interspersed to form a checkerboard pattern in the central portion of the core, with the highest enrichment fuel contained in the periphery. The pellets are slightly dished to better accommodate thermal expansion and fuel swelling, and to increase the void volume for retention of fission products that are released from the fuel matrix. The pellets are contained in ZIRLO (an advanced zirconium-based alloy) tubing,

Report

OPG Proprietary		
Document Number: N-REP-01200-10000	Usage Classification: N/A	
Sheet Number: N/A	Revision Number: R006	Page: 130 of 147

Title:

Use of Plant Parameters Envelope to Encompass the Reactor Designs being considered for the Darlington Site

which is plugged and seal-welded at the ends to encapsulate the fuel. The fuel rod is designed with upper and lower plenums to accommodate fission gas release. The fuel rods are also internally pressurized with helium to minimize clad stresses under reactor coolant operating pressures and aid in heat conduction. Reloaded cores are anticipated to operate approximately 18 months between refueling and studies have shown that the AP1000 reactor can also operate with a full core loading of MOX fuel.

Special Safety Systems

There are two passive safety systems: the Passive Core Cooling System (PXS), which is located within the containment vessel and provides direct cooling to the reactor (refer to Figure 2); and the Passive Containment Cooling System (PCS).

The containment shield building is designed such that outside cooling air will pass upwards along the sides of the containment vessel and rise towards an outlet at the top of the structure. Under accident conditions, the steel containment vessel enables heat transfer from inside containment to the outside cooling air. The air cooling is also supplemented by water evaporation on the surface of the containment vessel. This water is drained by gravity from a tank located on top of the containment shield building. This heat exchange system (refer to Figure 1) is designated the PCS. As a result of this unique design, no Ultimate Heat Sink is required for the AP-1000.

The PXS maintains core cooling by utilizing three sources of water: Core Makeup Tanks (CMTs), accumulators and an In-containment Refueling Water Storage Tank (IRWST).

Two CMTs are designed to accommodate small leaks in the RCS, using gravity as a driving force. The CMTs are also used during large loss of coolant accidents (LOCAs) to rapidly reflood the reactor core.

Two accumulators are designed to meet the need for higher initial makeup flows during large LOCAs. Gas pressure forces open check valves that normally isolate the accumulators from the RCS.

The IRWST provides long term injection water at low pressure (atmospheric) during a LOCA. Under such conditions, evaporating water from the RCS will rise towards the top of the containment vessel and condense on its cool inner surface (cool, due to the operation of the PCS), thus providing a means for heat exchange with the PCS. The condensed water is then collected in the IRWST, which is located near the base of the containment vessel, but still above the PCS. The IRWST in turn feeds the RCS. Long term cooling is therefore facilitated by this closed-loop cycle.

The PXS also contains a Passive Residual Heat Removal system (PRHR), to protect the plant against transient upsets to the steam generator feedwater and steam systems. The PRHR consists of a bank of tubes connecting the IRWST to the RCS in a natural circulation loop. The PRHR is normally isolated from the RCS by closed valves, which will fail open if power is lost.

The IRWST water volume is sufficient to absorb decay heat for about 2 hours before the water would start to boil. After that, steam will be generated and enter containment. This steam would then condense on the interior of the containment vessel and drain back into the IRWST in a similar closed loop cycle to the one described with respect to a LOCA.

Report

OPG Proprietary		
Document Number: N-REP-01200-10000	Usage Classification: N/A	
Sheet Number: N/A	Revision Number: R006	Page: 131 of 147

Title:
Use of Plant Parameters Envelope to Encompass the Reactor Designs being considered for the Darlington Site

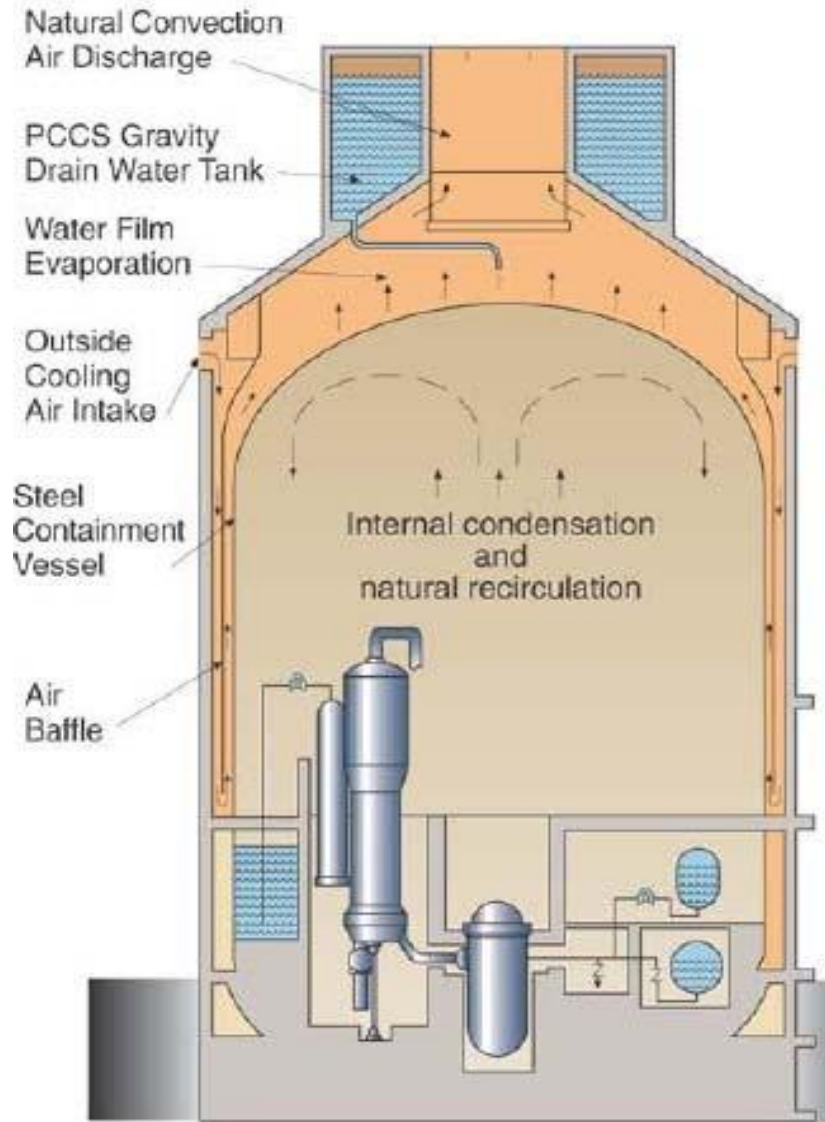

Figure 3

Report

OPG Proprietary		
Document Number: N-REP-01200-10000	Usage Classification: N/A	
Sheet Number: N/A	Revision Number: R006	Page: 132 of 147

Title:

Use of Plant Parameters Envelope to Encompass the Reactor Designs being considered for the Darlington Site

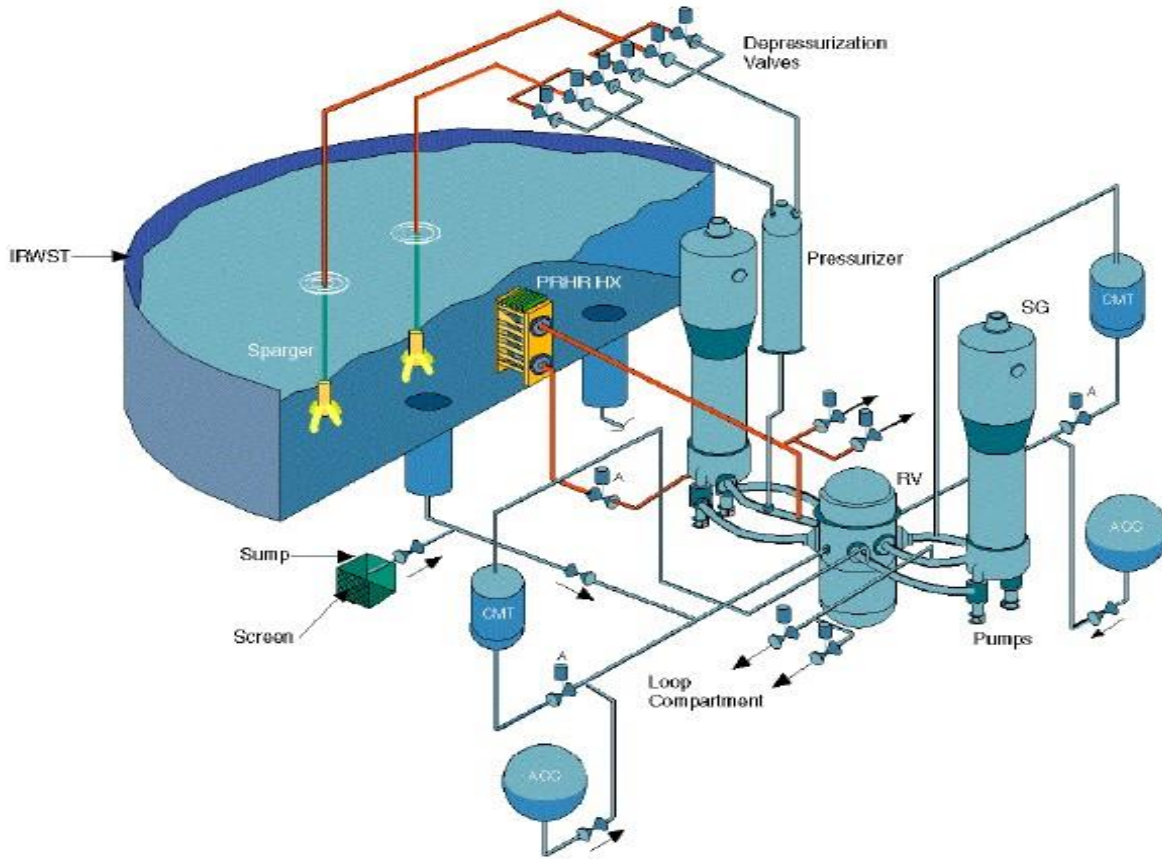

Figure 4

Report

OPG Proprietary		
Document Number: N-REP-01200-10000	Usage Classification: N/A	
Sheet Number: N/A	Revision Number: R006	Page: 133 of 147

Title:

Use of Plant Parameters Envelope to Encompass the Reactor Designs being considered for the Darlington Site

Atomic Energy of Canada Limited Advanced CANDU Reactor (ACR-1000)

Introduction

The Advanced CANDU Reactor (ACR) is a generation III+ reactor and is an evolution of the CANDU 6 design. Key changes include the use of light water coolant and Low Enriched Uranium (LEU) fuel to lower the reactivity coefficient under coolant void conditions. It also incorporates many of the design improvements to the most recent CANDU 6 plants in Qinshan, China as well as the improvements proposed for the Enhanced CANDU 6 (EC6).

The ACR-1000 is a scaled-up version of the first generation advanced CANDU, the ACR-700. The ACR-1000 is designed to generate 1165 MWe (gross), 3200 MWth, with a projected lifetime capacity factor of greater than 95% over 60 years.

Heat Transport System

The ACR Heat Transport System (HTS) coolant is light water instead of heavy water, which was used by previous generations of CANDU. This is possible due to the use of LEU fuel. The HTS comprises two “figure of eight loops”, each loop containing two steam generators and two HTS pumps circulating coolant for half of the reactor core (refer to Figure 1). In each loop, coolant picks up heat from the fuel in $\frac{1}{4}$ of the fuel channels (described in next subsection) in the core and then travels via outlet feeders to be collected in an outlet header. The coolant then passes to a steam generator, where heat is exchanged with a secondary cooling system. The cooled primary side coolant from the steam generator outlet then moves on to a heat transport pump that drives the coolant into an inlet header which supplies the coolant to the inlet feeders connected to a further $\frac{1}{4}$ of the fuel channels in the reactor core. The loop is then completed by an identical circulation sequence on the opposite side of the core.

Reactor Core

The ACR core (refer to Figure 2) has 520 fuel channels containing 12 fuel bundles per channel, horizontally arranged within a cylindrical vessel called a calandria, which is otherwise filled with heavy water moderator at pressure slightly above atmospheric and a temperature of approximately 80°C (measured at the calandria outlet). The moderator is cooled by an independent heat exchanger and circulation system and also acts as a passive heat sink under accident conditions. The reactor assembly comprises the calandria assembly which is located within a water-filled carbon steel-lined concrete structure (the calandria vault), fuel channel assemblies, and reactivity control units. The calandria vault is filled with light water that serves both as a radiation shield and as a cooling medium.

Local power regulation is provided by 23 zone control units, each consisting of two independently-controlled absorber elements with rectangular cross section, running in parallel vertical guide ways. When greater reactivity control is required, eight vertically mounted control absorbers are used.

Report

OPG Proprietary		
Document Number: N-REP-01200-10000	Usage Classification: N/A	
Sheet Number: N/A	Revision Number: R006	Page: 134 of 147

Title:

Use of Plant Parameters Envelope to Encompass the Reactor Designs being considered for the Darlington Site

The ACR also uses 32 dedicated guaranteed shutdown units, to ensure a guaranteed shutdown state without the need for the moderator poison system (which can be used however, when the GSS units are considered unavailable).

Each fuel channel comprises a zirconium alloy Pressure Tube (PT) inside a concentric Calandria Tube (CT), two endfittings, two closure plugs and 12 LEU fuel bundles. The PT, CT and the annulus between the PT and the CT separate the cool, low-pressure moderator from the hot, pressurized HTS coolant. The annulus between the PT and CT contains carbon dioxide, which can be tested for moisture to detect leaks. The end-fittings include closure plugs, which are accessible by robotic fuelling machines, and this allows for on-power fuelling. This feature eliminates the need for outages to replace fuel and helps increase the overall capacity factor of the ACR design.

Thick-walled PTs allow for a reactor inlet header pressure of about 12.5 MPa and a reactor outlet header temperature of 319°C in the HTS design. The use of elevated HTS coolant temperature and pressure allows for enhanced thermal efficiency.

Fuel Design

Since the light water in the HTS absorbs more neutrons than heavy water, ACR fuel must be slightly enriched. The ACR-1000 uses a 43 element fuel bundle (refer to figure 3) composed of 42 elements of (an average enrichment of) 2.5 wt% U235 around a central Dysprosium/Gadolinium oxide element in a stabilized Zirconium oxide matrix.

Special Safety Systems

The ACR-1000 has five special safety systems: Shutdown System 1 (SDS1), Shutdown System 2 (SDS2), the Emergency Core Cooling (ECC) System, the Emergency Feedwater (EFW) System and the Containment System.

The two safety shutdown systems are physically and functionally separate from each other and from the reactor regulating system, which is used to control reactor power during normal operation. Each SDS is independently capable of shutting down the reactor and operates passively once tripped. SDS1 consists of 46 mechanical shutoff rods that drop into the core by gravity upon receipt of a reactor trip signal. SDS2 uses pressurized tanks to inject concentrated gadolinium nitrate solution into the moderator through nozzles spanning the calandria.

Emergency core cooling is carried out by two systems: the Emergency Coolant Injection (ECI) system and the Long Term Cooling (LTC) system. The ECI system is used for high-pressure coolant injection into the HTS after a loss of coolant accident (LOCA). The ECI system consists of accumulators pressurized by compressed nitrogen gas, connected to the inlet and outlet headers and Core Makeup Tanks (CMTs) located at an elevation above the tops of the steam generator, connected to the discharge of each of the heat transport pumps. When the HTS pressure drops below the pressure of the ECI accumulators, passive check valves open. The CMTs limit the extent and duration of HTS voiding for secondary side depressurization events, and provide passive make-up water to the intact HTS loop during a LOCA.

The LTC system is used to provide fuel cooling in the later stage of a LOCA as well as for other accidents and transients. It does so by first utilizing inventory from Grade Level

Report

OPG Proprietary		
Document Number: N-REP-01200-10000	Usage Classification: N/A	
Sheet Number: N/A	Revision Number: R006	Page: 135 of 147

Title:

Use of Plant Parameters Envelope to Encompass the Reactor Designs being considered for the Darlington Site

Tanks (GLTs) and subsequently by recirculating ejected coolant water recovered from sumps located at the base of the reactor building.

The EFW system is designed to provide cooling water to the steam generators secondary side to enable the steam generators to transfer the decay heat to the ultimate heat sink. The EFW system has its own dedicated source of water, which is stored in the emergency feedwater tanks, located outside of the reactor building, to refill the secondary side of the steam generators.

The containment barrier is established using a combination of structures, isolation devices, and metallic extensions of the containment envelope. In addition to the steel-lined, concrete reactor building, the containment system includes airlocks, process penetrations (with automatic isolation where appropriate, in the case of an accident) and electrical penetrations together with subsections, where needed for reducing containment internal pressure, controlling hydrogen concentrations, and limiting the release of radioactive material to the environment following an accident.

The reserve water system (RWS) provides an emergency source of water to the steam generators, a containment cooling spray system moderator system, shield cooling system and heat transport system if required. Inventory for the reserve water system is held in the reserve water tank, which is located at a high elevation in the reactor building (refer to Figure 4), and provides a gravity-fed supply to interfacing systems.

OPG Proprietary		
Document Number: N-REP-01200-10000	Usage Classification: N/A	
Sheet Number: N/A	Revision Number: R006	Page: 136 of 147

Title:
Use of Plant Parameters Envelope to Encompass the Reactor Designs being considered for the Darlington Site

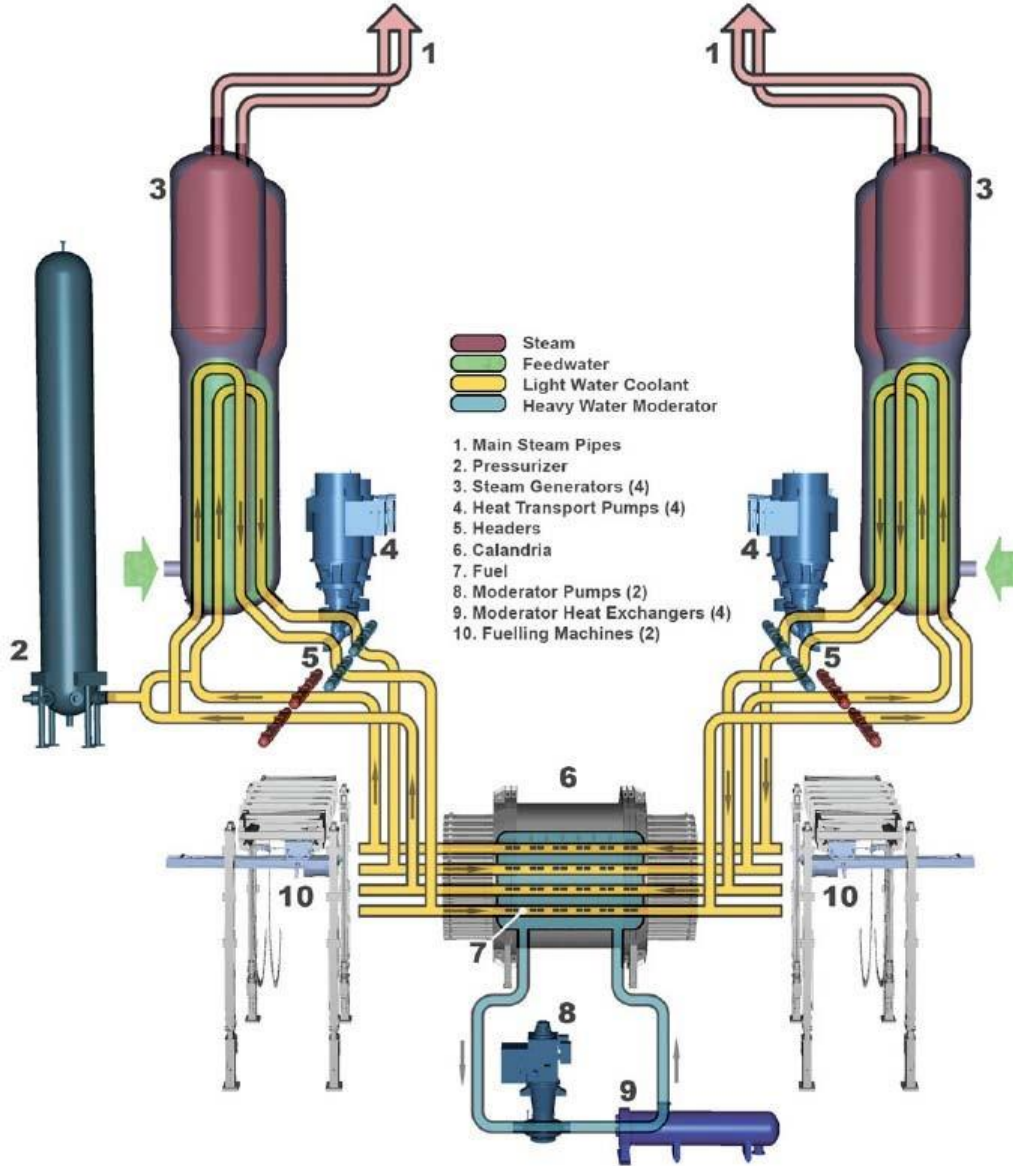

Figure 5

Report

OPG Proprietary		
Document Number: N-REP-01200-10000	Usage Classification: N/A	
Sheet Number: N/A	Revision Number: R006	Page: 137 of 147

Title:
Use of Plant Parameters Envelope to Encompass the Reactor Designs being considered for the Darlington Site

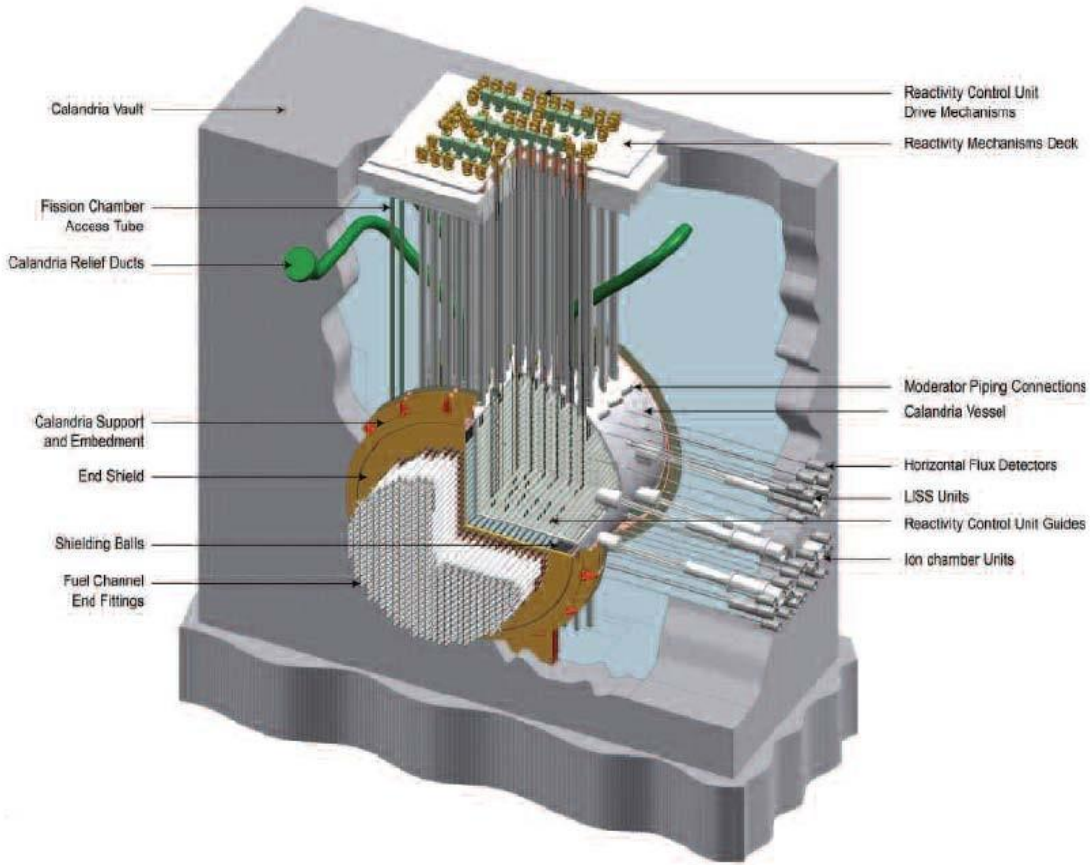

Figure 6



Figure 7

Report

OPG Proprietary		
Document Number: N-REP-01200-10000	Usage Classification: N/A	
Sheet Number: N/A	Revision Number: R006	Page: 138 of 147

Title:
Use of Plant Parameters Envelope to Encompass the Reactor Designs being considered for the Darlington Site

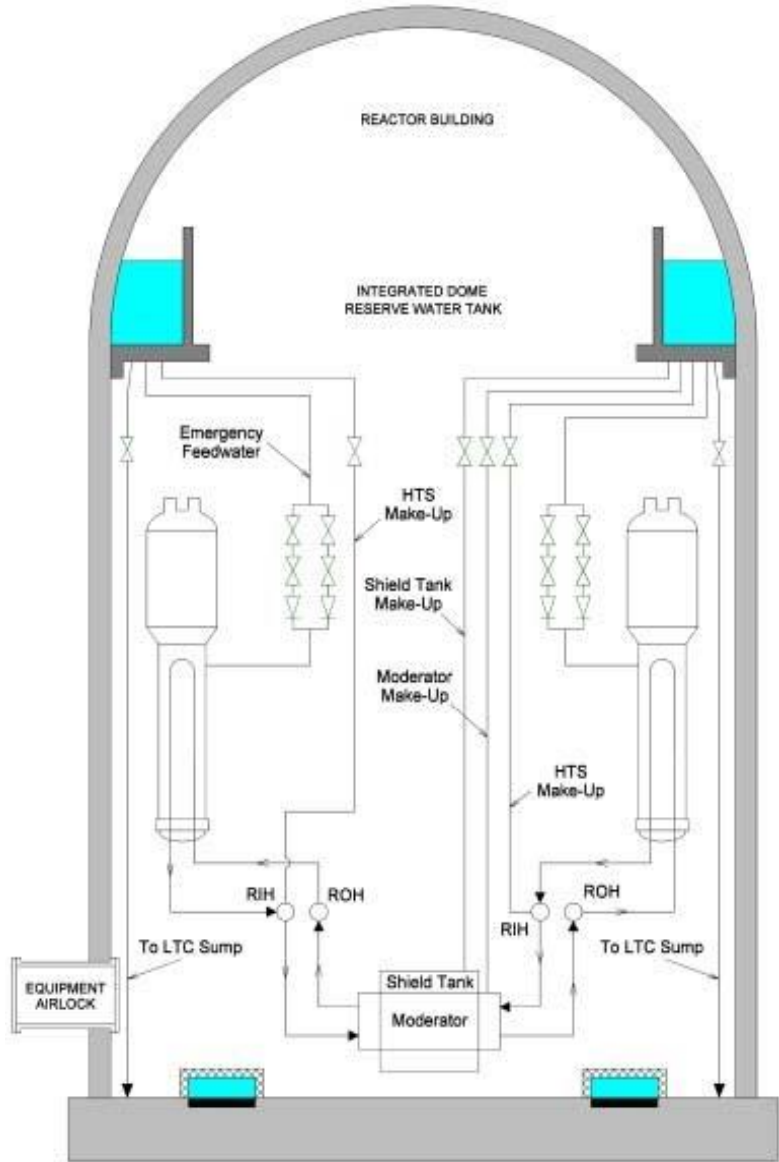

Figure 8

Report

OPG Proprietary		
Document Number: N-REP-01200-10000	Usage Classification: N/A	
Sheet Number: N/A	Revision Number: R006	Page: 139 of 147

Title:

Use of Plant Parameters Envelope to Encompass the Reactor Designs being considered for the Darlington Site

Atomic Energy of Canada Limited Enhanced CANDU 6 Reactor (EC6)

Introduction

The Enhanced CANDU 6 Reactor (EC6) is a generation III reactor and is an evolution of the CANDU 6 design. The design incorporates feedback from operating reactors, including the most recent CANDU 6 plants in Qinshan, China. Like the currently operating plants, the EC6 can be fuelled online, uses natural uranium, and incorporates 2 independent fast-acting shutdown systems. The EC6 design enhancements include extended operational life, additional accident resistance, and improved containment design to mitigate beyond design basis accidents and human induced events. The EC6 is designed to generate 740 MWe (gross), 2100 MWth, with a projected lifetime capacity factor of greater than 90% over 60 years operating life.

Heat Transport System

The EC6 Heat Transport System (HTS) coolant is heavy water, like previous generations of CANDU. The HTS comprises two “figure of eight loops”, each loop containing two steam generators and two HTS pumps circulating coolant for half of the reactor core (refer to Figure 1). In each loop, coolant picks up heat from the fuel in $\frac{1}{4}$ of the fuel channels (described in next subsection) in the core and then travels via outlet feeders to be collected in an outlet header. The coolant then passes to a steam generator, where heat is exchanged with a secondary cooling system. The cooled primary side coolant from the steam generator outlet then moves on to a heat transport pump that drives the coolant into an inlet header which supplies the coolant to the inlet feeders connected to a further $\frac{1}{4}$ of the fuel channels in the reactor core. The loop is then completed by an identical circulation sequence on the opposite side of the core.

The feeders are being enhanced to address experience from the operating CANDU reactors.

Reactor Core

The EC6 core (refer to Figure 2) has 380 fuel channels containing 12 fuel bundles per channel, horizontally arranged within a cylindrical vessel called a calandria, which is otherwise filled with

heavy water moderator at pressure slightly above atmospheric and a temperature of approximately 69°C (measured at the calandria outlet). The moderator is cooled by an independent heat exchanger and circulation system and also acts as a passive heat sink under accident conditions. The reactor assembly comprises the calandria assembly which is located within a water-filled carbon steel-lined concrete structure (the calandria vault), fuel channel assemblies, and reactivity control units. The calandria vault is filled with light water that serves both as a radiation shield and as a cooling medium.

Local power regulation is provided by liquid zone control units, which introduce light water in zircalloy tubes to act as a neutron absorber and control the power of the reactor. The reactor regulating system also includes control absorber units and adjusters.

Each fuel channel comprises a zirconium alloy Pressure Tube (PT) inside a concentric Calandria Tube (CT), two endfittings, two closure plugs and 12 natural uranium fuel

Report

OPG Proprietary		
Document Number: N-REP-01200-10000	Usage Classification: N/A	
Sheet Number: N/A	Revision Number: R006	Page: 140 of 147

Title:

Use of Plant Parameters Envelope to Encompass the Reactor Designs being considered for the Darlington Site

bundles. The PT, CT and the annulus between the PT and the CT separate the cool, low-pressure moderator from the hot, pressurized HTS coolant. The annulus between the PT and CT contains carbon dioxide, which can be tested for moisture to detect leaks. The end-fittings include closure plugs, which are accessible by robotic fuelling machines to allow for on-power fuelling. This feature eliminates the need for outages to replace fuel and helps increase the overall capacity factor of the EC6 design.

Thick-walled PTs allow for a reactor inlet header pressure of about 11.2 MPa and a reactor outlet header temperature of 310°C in the HTS design. The use of elevated HTS coolant temperature and pressure allows for enhanced thermal efficiency.

Fuel Design

The EC6 uses a 37 element fuel bundle (refer to figure 3) composed of 37 zirconium alloy tubes containing the fuel pellets. The fuel is natural uranium with 0.71 wt% of U-235.

Special Safety Systems

The accident resistance of the EC6 has been enhanced, including improved performance of shutdown system 1, more resistant containment design, and the addition of an emergency heat removal system. The EC6 has five special safety systems: Shutdown System 1 (SDS1), Shutdown System 2 (SDS2), the Emergency Core Cooling (ECC) System, the Containment System, and the Emergency Heat Removal System (EHRS).

The two safety shutdown systems are physically and functionally separate from each other and from the reactor regulating system, which is used to control reactor power during normal operation. Each SDS is independently capable of shutting down the reactor and operates passively once tripped. SDS1 consists of 28 mechanical shutoff rods that drop into the core by gravity upon receipt of a reactor trip signal. SDS2 uses pressurized tanks to inject concentrated gadolinium nitrate solution into the moderator through nozzles spanning the calandria.

Emergency core cooling is carried out by three sub-systems: the High Pressure Emergency Core Cooling (HPECC) system, the Medium-Pressure Emergency Core Cooling (MPECC) system, and the Low-Pressure Emergency Core Cooling (LPECC) system. The HPECC system is used to supply high-pressure coolant injection into the HTS after a loss of coolant accident (LOCA). The HPECC consists of water-filled accumulators pressurized by compressed gas, activated when the pressure in the HTS system drops below the pressure of the HPECC accumulator tanks. The MPECC system injects water from the reserve water tank into the HTS when the coolant pressure has decreased below specific levels. The LPECC system is used in the longer term following a LOCA to provide recirculation and recovery. The LPECC system is initiated when the HTS depressurizes below a specific pressure. The LPECC pumps recirculate ejected coolant water recovered from sumps located at the base of the reactor building.

The containment barrier is established using a combination of structures, isolation devices, and metallic extensions of the containment envelope. In addition to the steel-lined, pre-stressed concrete reactor building, the containment system includes airlocks, process penetrations (with automatic isolation where appropriate, in the case of an accident) and electrical penetrations together with subsections, where needed for reducing containment internal pressure, controlling hydrogen concentrations, and limiting

Report

OPG Proprietary		
Document Number: N-REP-01200-10000		Usage Classification: N/A
Sheet Number: N/A	Revision Number: R006	Page: 141 of 147

<small>Title:</small> Use of Plant Parameters Envelope to Encompass the Reactor Designs being considered for the Darlington Site
--

the release of radioactive material to the environment following an accident. Local air coolers remove heat from the containment atmosphere. A spray system connected to the elevated reserve water tank is used to reduce the reactor building pressure, if required, in the event of severe accidents.

The EHRS system is designed to provide cooling water to the secondary side of the steam generators to enable the steam generators to transfer the decay heat to the ultimate heat sink. The EHRS has its own dedicated source of water located outside the reactor building to refill the secondary side of the steam generators. Following a severe accident, EHRS can also provide makeup water to the containment system, moderator, and calandria vault within the containment, if required.

The Reserve Water System (RWS) provides an emergency source of water to the calandria vessel, calandria vault, steam generators, ECC system, primary heat transport system via the ECC system, and a containment cooling spray system. Inventory for the reserve water system is held in the reserve water tank, which is located at a high elevation in the reactor building, and provides a gravity-fed supply to the interfacing systems.

Report

OPG Proprietary		
Document Number: N-REP-01200-10000	Usage Classification: N/A	
Sheet Number: N/A	Revision Number: R006	Page: 142 of 147

Title:

Use of Plant Parameters Envelope to Encompass the Reactor Designs being considered for the Darlington Site

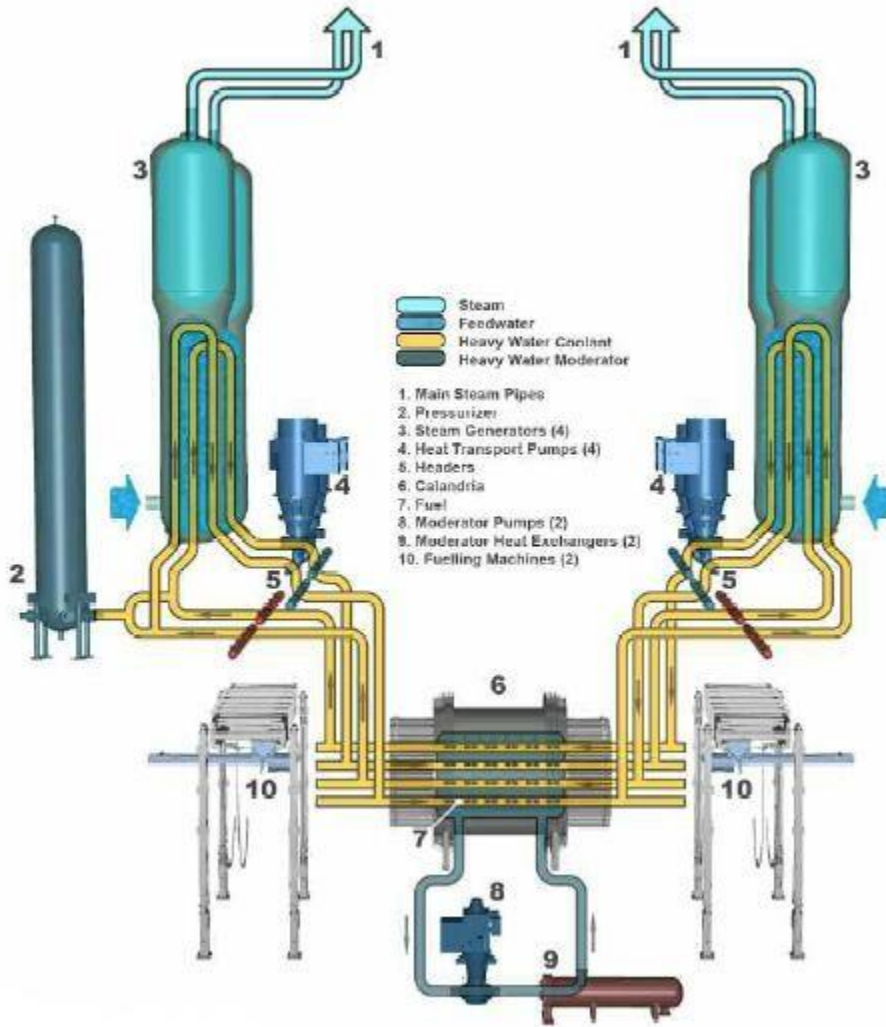

Figure 9

Report

OPG Proprietary		
Document Number: N-REP-01200-10000	Usage Classification: N/A	
Sheet Number: N/A	Revision Number: R006	Page: 143 of 147

Title:
Use of Plant Parameters Envelope to Encompass the Reactor Designs being considered for the Darlington Site

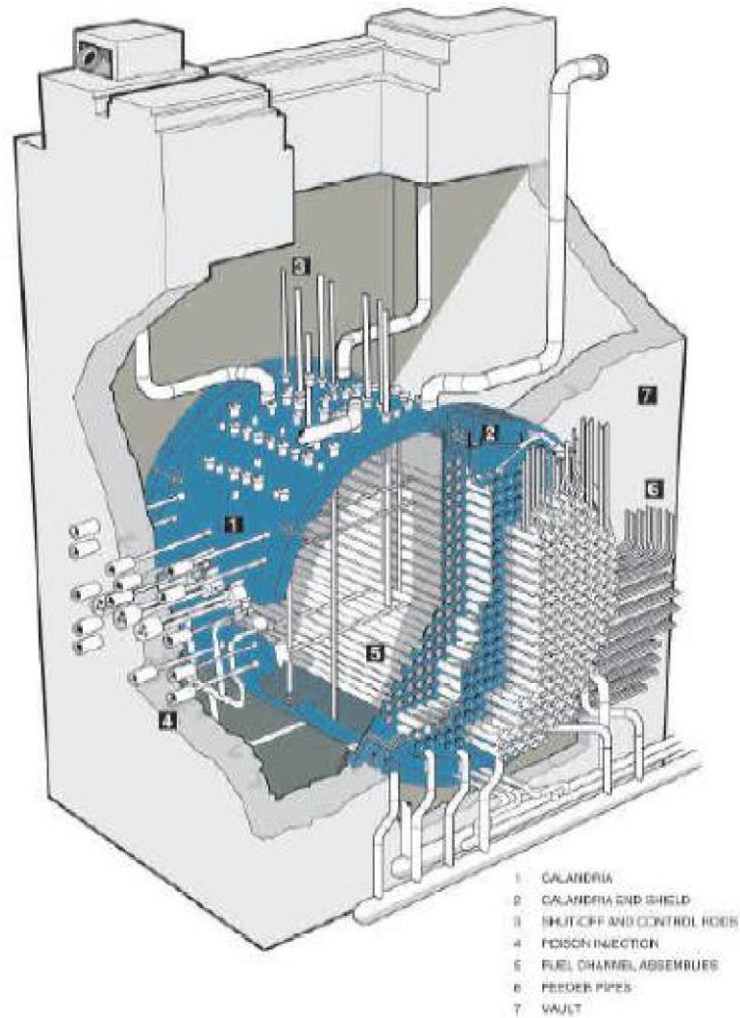

Figure 10

Report

OPG Proprietary		
Document Number: N-REP-01200-10000		Usage Classification: N/A
Sheet Number: N/A	Revision Number: R006	Page: 144 of 147

Title:
Use of Plant Parameters Envelope to Encompass the Reactor Designs being considered for the Darlington Site



Figure 11

Report

OPG Proprietary		
Document Number: N-REP-01200-10000	Usage Classification: N/A	
Sheet Number: N/A	Revision Number: R006	Page: 145 of 147

Title:

Use of Plant Parameters Envelope to Encompass the Reactor Designs being considered for the Darlington Site

GEH BWRX-300

Introduction

The BWRX-300 is a 300 MWe water-cooled, natural circulation Small Modular Reactor (SMR) with passive safety systems that leverages the design and licensing basis of GEH's U.S. NRC-certified ESBWR. The BWRX is the tenth evolution of GE Boiling Water Reactor (BWR) designs.

Like most boiling water reactors, the BWRX-300 will use low pressure light water to remove heat from the core. A distinct feature of this reactor design is that water is circulated within the core by natural circulation.

The BWRX-300 uses a deeply embedded reactor building 38 meters below DNNP plant grade. The RPV is a vertical, cylindrical pressure vessel with details shown in Figure 12.

Fuel Design

The BWRX utilizes the NRC licensed GNF2 fuel design which uses a square fuel bundle. The fuel is a uranium oxide.

Special Safety Systems

One of the design objectives of the BWRX-300 Reactor Coolant Pressure Boundary (RCPB) is to minimize the risks associated with LOCAs relative to the ESBWR design. Risk is minimized by the following:

- Reducing the number of nozzles,
- Reducing pipe lengths and nominal pipe diameters,
- Maximizing the elevation of the nozzles,
- Use of a RPV isolation valve.

The BWRX-300 utilizes a natural circulation and passive cooling isolation condenser systems from the U.S. NRC-licensed ESBWR. Steam condensation and gravity allow the BWRX-300 to passively cool itself for seven days without power or operator action during abnormal events, including station blackout. The ICS consists of three independent trains, each containing a heat exchanger that condenses steam to the surrounding pool water by condensation and natural circulation. No forced circulation equipment is required.

Report

OPG Proprietary		
Document Number: N-REP-01200-10000		Usage Classification: N/A
Sheet Number: N/A	Revision Number: R006	Page: 146 of 147

Title:
Use of Plant Parameters Envelope to Encompass the Reactor Designs being considered for the Darlington Site

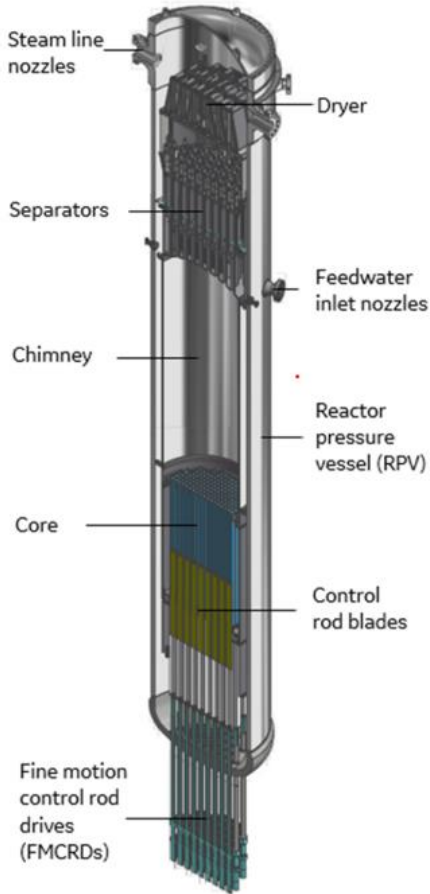

Figure 12: BWRX-300 Reactor Pressure Vessel and Internals

Report

OPG Proprietary		
Document Number: N-REP-01200-10000	Usage Classification: N/A	
Sheet Number: N/A	Revision Number: R006	Page: 147 of 147

Title:
Use of Plant Parameters Envelope to Encompass the Reactor Designs being considered for the Darlington Site

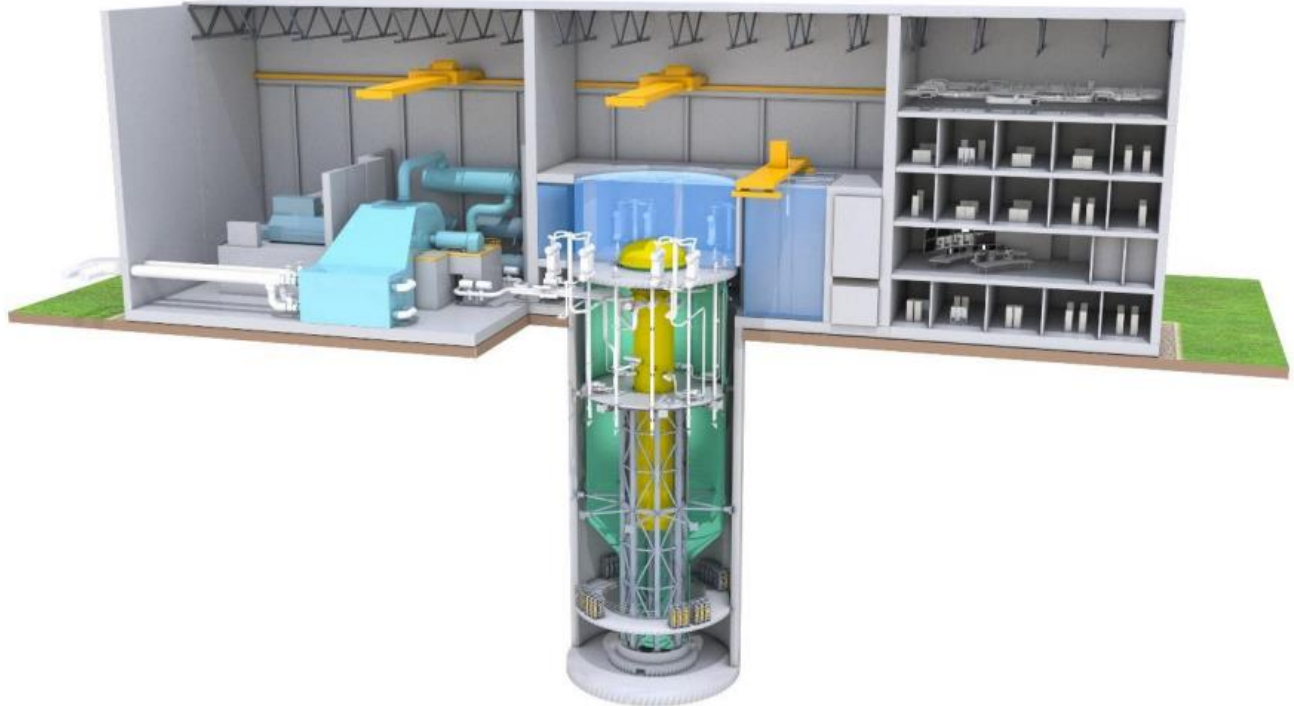

Figure 13: BWRX-300 Cross Section

References:

- [1] [NEDO-33910, Revision 0, "BWRX-300 Reactor Pressure Vessel Isolation and Overpressure Protection." \(nrc.gov\)](#)